

SPECIFICATIONS (Module H):

The new developed Hall Probe type Lx for the SENIS F3A magnetic field transducers and digital teslameters has a **ultra-thin probe tip (0.1 mm) with a naked Si-chip** going out of the ceramic package. The probe body thickness is 0.5 mm. This fully integrated 3-axis Hall Probe is available in three different lengths:

1. Long version (LL): 71 mm,
2. Medium (LM): 47 mm,
3. Small (LS): 8 mm.

The Hall Probe Lx for F3A Magnetic Transducers contains a CMOS integrated circuit, which incorporates three groups of mutually orthogonal Hall elements, biasing circuits, amplifiers, and a temperature sensor. The integrated Hall elements occupy very small area ($150\mu\text{m} \times 150\mu\text{m}$), which provides very high spatial resolution of the probe.

The CMOS IC technology enables very high precision in the fabrication of the vertical and horizontal Hall elements, which gives high angular accuracy (orthogonality error $< 0.1^\circ$) of the three measurement axes of the probe. The on-chip application of the spinning-current technique in the biasing of the Hall elements suppresses the planar Hall-effect. The on-chip signal pre-processing enables a very high frequency bandwidth (DC up to 25 kHz) of the probe, and on-chip signal amplification provides high output signals of the Hall probe.

The sensor chip is embedded in the probe package and connected to the CaH cable.

The outputs of the Hall Probe are high-level analog voltages proportional with each of the measured components of a magnetic flux density and a voltage proportional with the probe temperature.



KEY FEATURES OF THE 03Lx HALL PROBE SYSTEM

- The new Hall Probe type Lx has a ultra-thin probe tip (0.1 mm) with a naked single Si-chip going out from the ceramic substrate. The probe body thickness is 0.5 mm. The probe is available in 3 (three) different lengths (71 mm / 46 mm / 8 mm)
- The Kx probe type is particularly suitable for very small distances (air gap) between the probe's field sensitive spot and the surface of the magnetic material
- The probe package is fully made of Al_2O_3 ceramic, with the chip and cable connecting pads directly printed on the ceramic substrate
- Fully integrated CMOS 3-axis (B_x , B_y , B_z) Hall Probe, of which one, two, or three channels are used
- Very high spatial resolution (B_y : $0.03 \times 0.005 \times 0.03\text{mm}^3$; B_x and B_z : $0.15 \times 0.01 \times 0.15 \text{mm}^3$)
- High angular accuracy (orthogonality error less than 0.1°)
- High frequency bandwidth (DC up to 25kHz)
- Virtually no planar Hall effect
- Negligible inductive loops on the Probe
- Integrated temperature sensor on the probe for temperature compensation

PROBE AND CABLE - DIMENSIONS AND CHARACTERISTICS

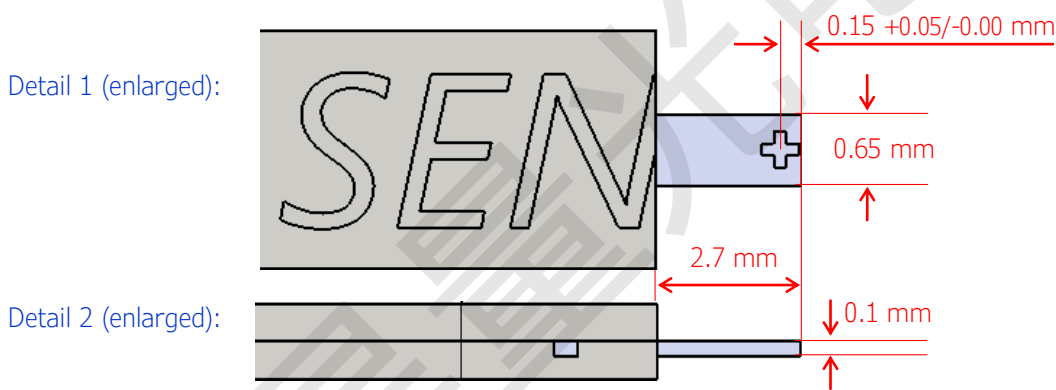
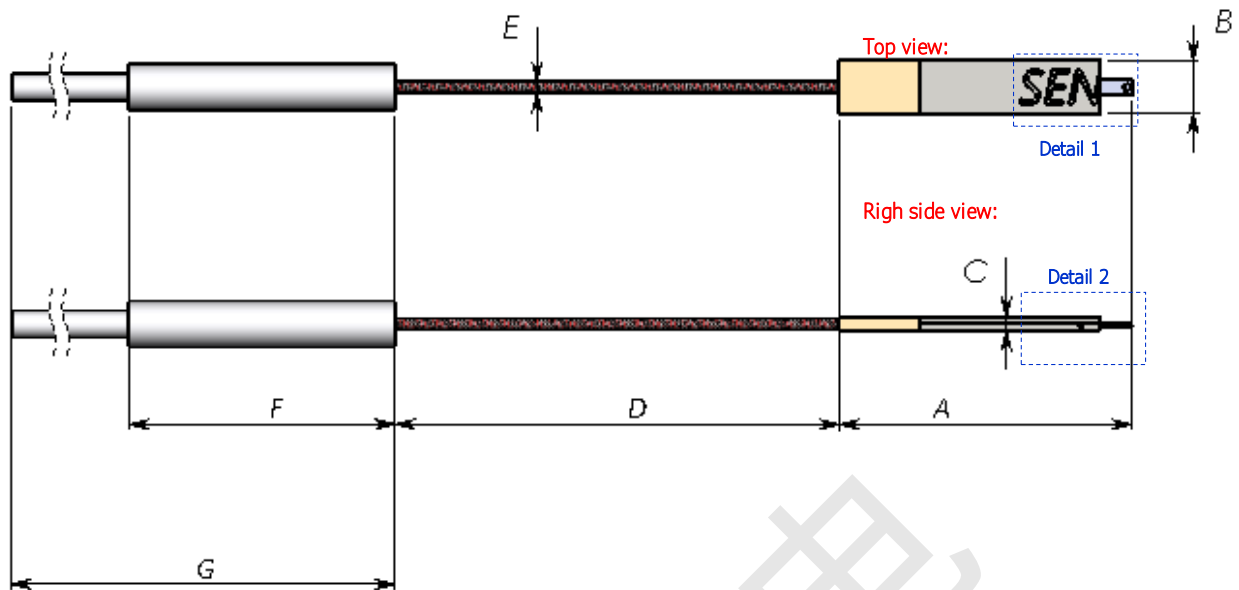

Dimension	Hall Probe Type		
	KL (long)	KM (medium)	KS (small)
A	71.0 ± 0.5 mm	46.0 ± 0.5 mm	8.0 ± 0.2 mm
B	2.00 ± 0.05 mm		
C	0.50 +0.05/-0.00 mm		
D	50 ± 1 mm		
E	Ø 0.8 ± 0.1 mm		
F	25 ± 2 mm		
G	The standard Cable lengths are: 2m, 5m and 10m. Optionally, different cable lengths are available, on a demand.		

Figure 1. Dimensions and tolerances of the new Hall probe Type Lx and cable CaH (Module H)

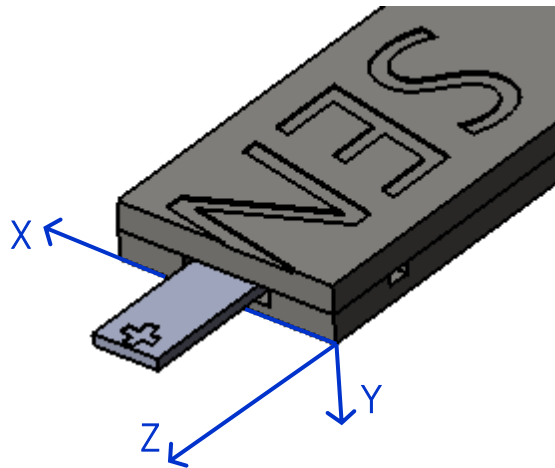

Figure 2: Reference Cartesian coordinate system of the 03Lx Hall probe

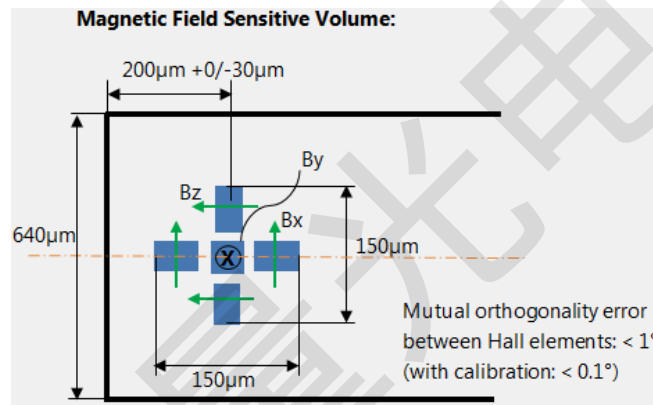

Figure 3: Overall magnetic field sensitive volume (MFSV) of the applied fully integrated 3D Hall sensor

Probe Dimensions & Characteristics			
Dimension	X [mm]	Y [mm]	Z [mm]
Magnetic field sensitive volume (MFSV) (see Fig. 3)	0.15	0.01	0.15
Position of the centre of MFSV (Fig. 1 and 2)	1.0 ± 0.1	-0.25 +0.05/-0.00	2.7 ± 0.1
Total Probe external dimensions	2.0 ± 0.1	Probe body: 0.50 +0.05/-0.00 Probe tip: 0.10	version LL: 71.0 ± 0.5 version LM: 46.0 ± 0.5 version LS: 8.0 ± 0.2
Angular accuracy of the axes	±0.5° with respect to the reference surface		
CaH Cable	Shielded, with a flexible thin part near the probe		

INSTALLATION MANUAL FOR THE 03Lx HALL PROBE



NOTE: The Probe tip is fragile! Please handle it with a special care.

The probe package is made of the two thin ceramic plates and can be easily broken. Therefore, avoid any mechanical contact of the probe tip with other objects! Moreover, avoid the immersion of the probe of any liquid, and its exposure to moisture and aggressive gasses.

The following precautions shall help ensure that the transducer accurate calibration remains preserved:

- The mounting of the probe should be carried out by application of very low pressure to its back-end and thin wires.
- If the probe head is clamped, the user should make sure that the substrate surface in contact with the reference plane of the probe is flat and covers as much of the probe reference surface as possible.
- Do not apply more force than required to hold the probe in its place. Damage of the silicon Hall sensor or ceramic package will destroy the Probe. We strongly suggest storing the probe in its protective case when not in use.
- In order to prevent rupture of the thin wires from the probe head, the user should fix and secure the probe cable in the proximity of the probe. The thin wires of the flexible section of the cable may be folded with care. Repeated strong bending should be avoided.
- Avoid any high pressure and bending of the transient section between the thin and the thick cables:
- When the probe head is mounted, the cable should be firmly clamped nearby so it cannot be torn away from the probe head if accidentally pulled. The flexible section adjacent to the probe head can be carefully folded to allow the cable to come away in any direction, but avoid repeated flexing of this section.
- Keep the cable out of the way of foot traffic. Do not pinch the cable, or drop sharp or heavy objects on it. A severed cable cannot be re-joined without altering the probe's performance, and requires factory repair and a full re-calibration of the device.
- The first ensure that the Electronic module is not powered. If so, carefully plug the Probe connector (female SUB-D/25-pins connector) to the corresponding male SUB-D/25-pins connector on the electronic box. Ensuring that its pins engage correctly, tighten the metal screws of the probe connector. Do not leave these loose since they are the component part of the shielding system of the transducer.
- **Since the Hall sensor is sensitive to electrostatic discharge (ESD) the user must be sure to ground himself and to follow proper procedure when handling the sensor.**