

Nanopore Reader 100 kHz

The **Nanopore Reader 100 kHz** is a compact and portable read-out device with miniaturized flow cells for **ultra-low noise recordings of solid state nanopores, biological pores and nanoparticle detection.**



This device can be used for experimental activities such as resistive pulse sensing, single molecule detection, DNA translocation and single channel recordings in artificial lipid membranes. Thanks to its size and high-resolution data collection, when combined with the specific nanosensor, this unit is a versatile platform suitable for different applications, from water quality monitoring, environmental pollution analysis and disease marker detection.

Technical specifications:

- ◆ Open input (RMS) noise (Voltage range $\pm 700\text{mV}$): 0.06 pA rms @ 625Hz; 0.3 pA rms @ 10kHz; 2.4pA rms @ 100kHz
- ◆ Open input (RMS) noise (Voltage range $\pm 2000\text{mV}$): 0.08 pA rms @ 1kHz; 0.42 pA rms @ 10 kHz; 3.7 pA rms @ 100 kHz
- ◆ Current ranges: $\pm 200\text{pA}$ (Gain 2.25G Ω), $\pm 2\text{nA}$ (Gain 225M Ω), $\pm 20\text{nA}$ (Gain 22.5M Ω), $\pm 200\text{nA}$ (Gain 2.25M Ω)
- ◆ Voltage pulse generator range of $\pm 2000\text{ mV}$
- ◆ Parametric voltage protocols
- ◆ Available bandwidth between 62,5 Hz and 100 KHz
- ◆ Max sampling rate: 200 kS/s
- ◆ Auto electrodes voltage offset fine compensation
- ◆ USB powered
- ◆ Size & Weight: 101 x 44 x 18 mm, 140 g

Nanopore FlowCell and BLMchip

Depending on the application, different flow cells are available:

the BLM chips, the Nanopore Flow Cells and the new Micropore Flow Cells



The BLMchips (top) are designed for biological pores. A layer of Polyimide, 12.5 μm thick, hosts the micro hole available in two different sizes (100 μm and 150 μm). The BLMchip design allows an easy access to the buffer solution in both the chambers (60 μl bottom, 60 μl top) by pipetting. Ag/AgCl electrodes are integrated in the chip ready to be connected to eNPR device.

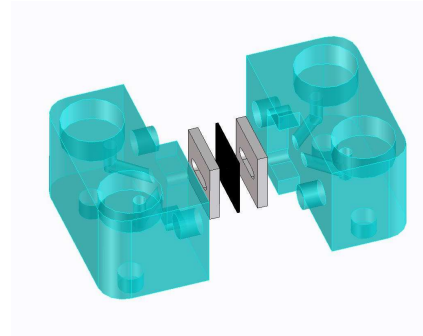
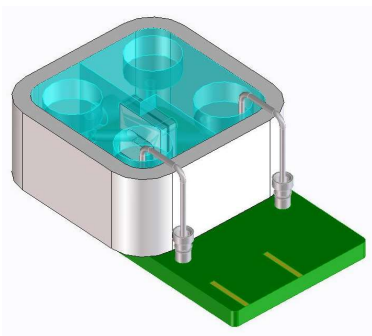

The Nanopore Flow Cell integrates the nanopore slot hosting a 5×5 mm squared and 200 μm thick nanopore chip (black square in the exploded view). Two compartments for fluids (min 10 μl, max 60 μl volume) and the Ag/AgCl electrodes complete this mini flow cell with a size of only 18x28x10 mm.

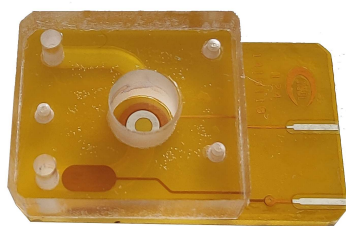

New: recently, we have designed a micropore sensor for nanoparticles detection in fluids (bottom). The high precision 0.9 μm sized hole embedded in a 12.5 μm thick layer of Polyimide enables the counting and sizing of nanoparticles using the resisting pulse sensing method.

EDR3, Elements data reader software interface

EDR3 software is the electrophysiology software developed and released by Elements for a handy control of the Nanopore Reader 100 kHz device.

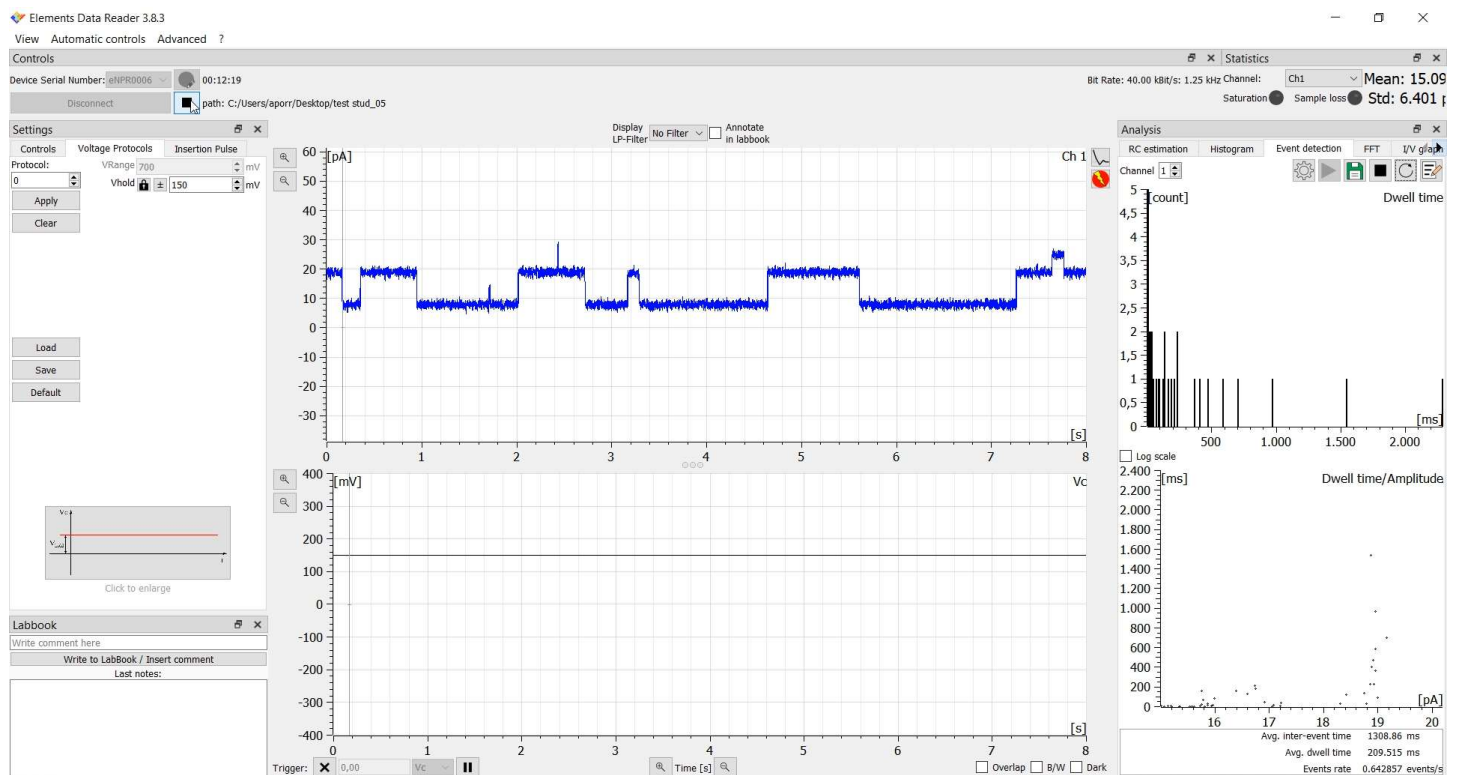

The figure shows a snapshot of the EDR3 software interface while measuring the single channel activity of the channel-forming ionophore Gramicidin D. The “event detection” tool automatically builds in real time the dwell time analysis graphs. Raw data of the analysis can be exported as .csv file.

Features:

- ◆ Customizable user-friendly Windows-format interface
- ◆ Real-time display of voltage and current digitized data
- ◆ Parametric voltage protocols editor
- ◆ Continuous Capacitance and Resistance monitoring during the recording
- ◆ Real-time data analysis (I/V graph, event detection, dwell time, FFT, noise detection etc.)
- ◆ Digital LabBook
- ◆ Two data output saving formats: .dat and .abf
- ◆ Ultra-low noise modality for a 30% reduction of the noise (voltage pulse generator range reduced to ± 700 mV).

Case studies

Recordings from BLMchips

The combination of high performance and low cost makes the Nanopore Reader 100 KHz a powerful device for ultra-low noise single channel recordings in artificial lipid bilayers.

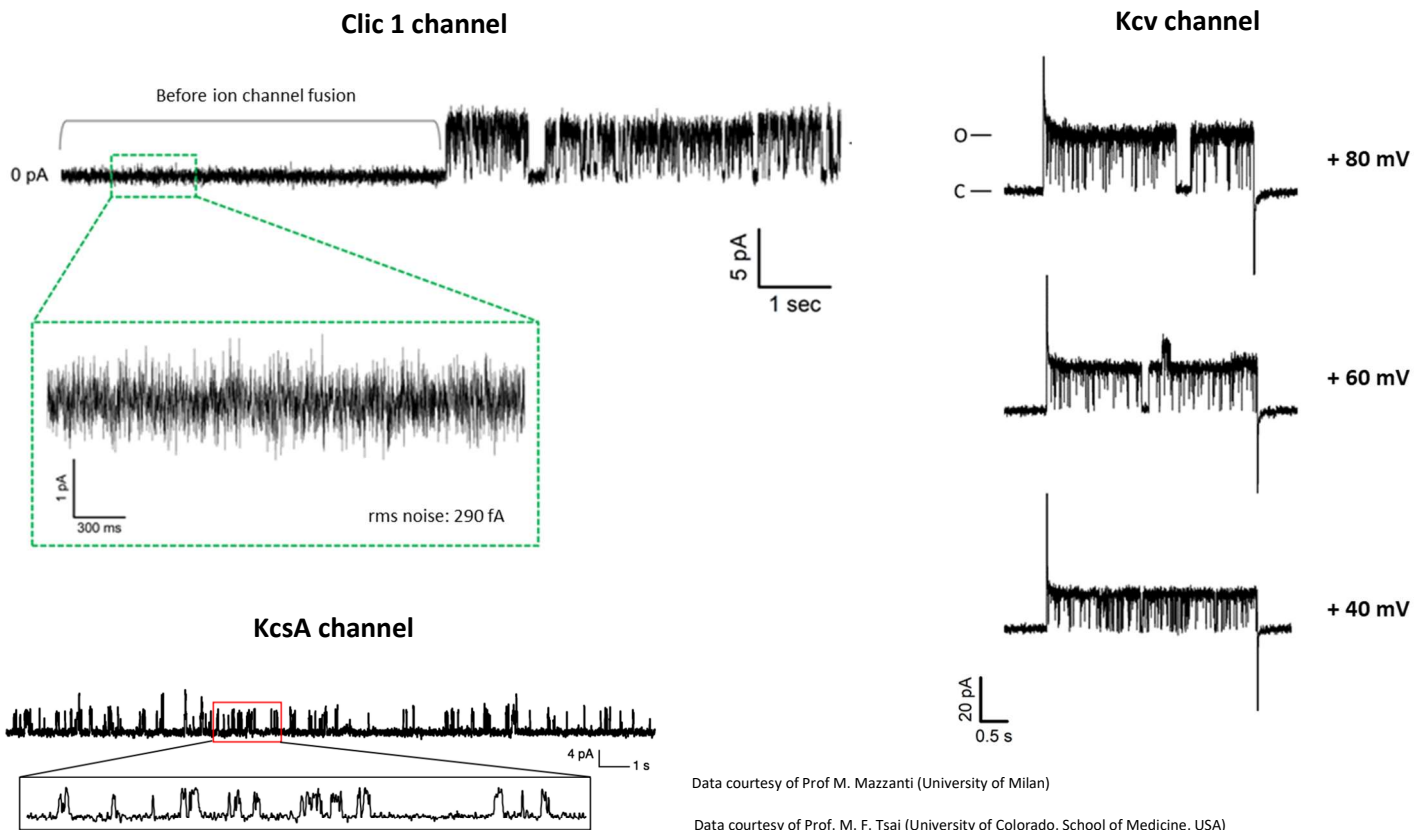

Measurement from Nanopore Flow Cells

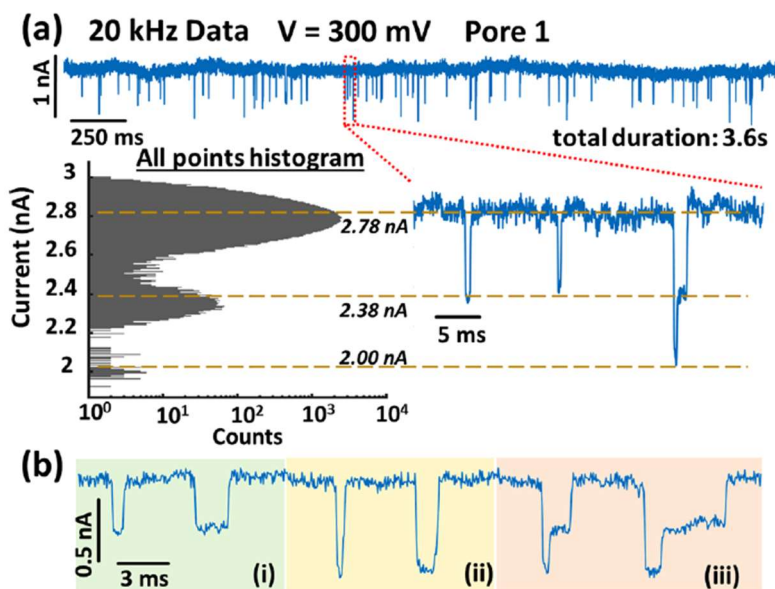

DNA translocations through HF-etched SiN_x nanopores in 1 M KCl.

(a) Current vs time trace (3.6 s long) after addition of 1 kbp dsDNA at $V = 300$ mV, all-points histogram, and zoom-in view on one section of the trace. The trace was recorded at 20 kHz bandwidth. The calculated pore diameter from the open pore current is 4.8 nm assuming a thickness of 20 nm.

(b) Three types of events shown from (i) to (iii), where DNA is unfolded, fully folded, and partially folded, respectively are detected. The agreement between G , ΔG (for unfolded DNA), and ΔG (for folded DNA) with the measured values provides evidence for single pore formation.

Zehui Xia, Andre Scott, Rachael Keneipp, Joshua Chen, David J. Niedzwiecki, Brian DiPaolo, and Marija Drndić. *Silicon Nitride Nanopores Formed by Simple*