

aMSM UV/VIS SENS

A. Microspectrometer Module

The Microspectrometer is based on a hollow cavity waveguide design which has no moving parts. It is attached to a photodiode detector array. The light is coupled into the spectrometer through a 300/330 μ m silica fiber and entrance slit. The light is guided by total reflection inside the spectrometer cavity.

The spectrometer itself is a micro-molded monolithical device which includes the entrance slit, a focusing flat field echelette grating and the camera mirror. These elements are arranged in the Rowland design.

The microstructures are replicated with optical surface quality using the LIGA technology.

The monolithic Rowland design guarantees superior mechanical, thermal and optical stability. There is virtually no thermal drift of the wavelength calibration due to the fixed geometrical position of the optical components.

The wavelength to pixel calibration function is stable over the lifetime of the product and will not require any recalibration.

The low weight and the monolithic design make it insensitive to mechanical as well as vibrational stress. The fabrication processes and the use of selected materials ensure excellent resistance against thermal stress and demanding environmental conditions.

The UV/VIS Microspectrometer uses the Hamamatsu S13014-10 silicon-photodiode array.

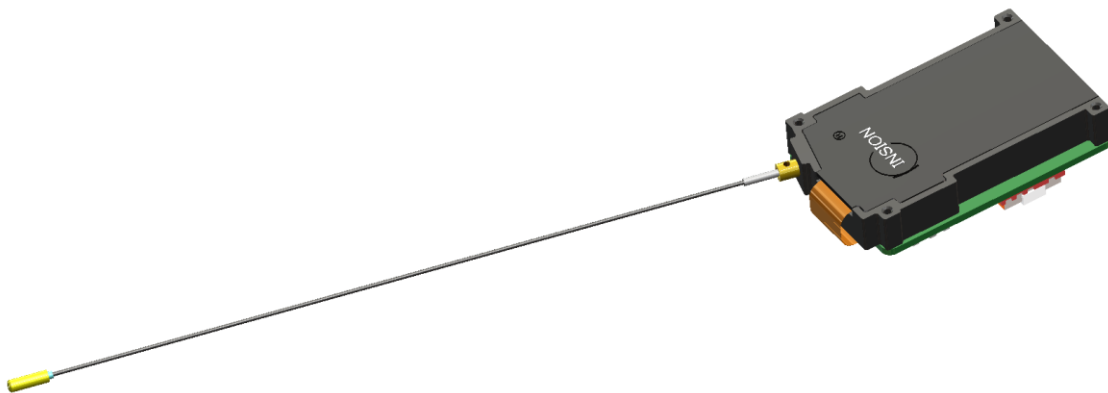

Product Information

These features make the Microspectrometer an ideal choice for the incorporation into spectral sensing devices for applications involving harsh environmental conditions. Handheld battery driven devices as well as in-line process sensors utilize the Microspectrometer. Typical applications range from instrumental analysis, biological and clinical systems to colorimeters, food inspection systems and fluorescence measuring devices.

Our Injection Micro-molding technology guarantees excellent inter instrument agreement as well as a very attractive pricing, especially in OEM volumes.

B. Dimensions of aMSM UV/VIS SENS spectrometer

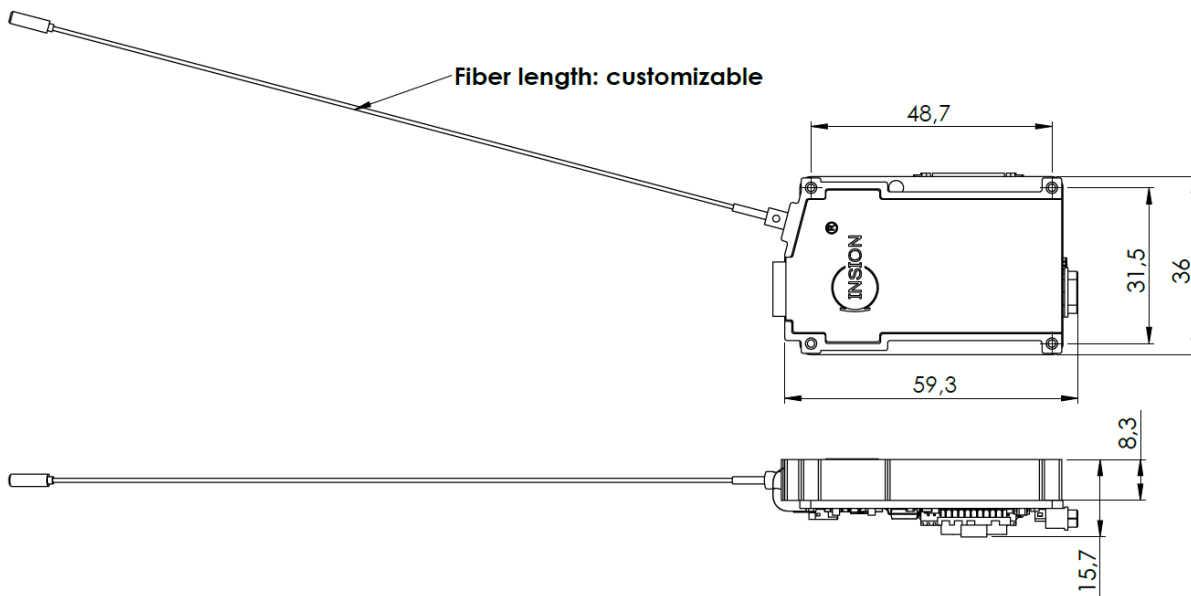

C. Technical Data

Spectral Range	350-850 nm (280-1050 nm accessible)
Fiber	Ø 300/330 µm NA = 0.22
Straylight Attenuation	>18dB with GG495 at 470nm (30 dB using SC30)
Spectral Resolution	8 nm _{FWHM} (Sp. Disp. 1.96 nm/pixel)
Spectral Accuracy	2 nm
Dynamic Range	>5000
Inter Instrument Agreement	Typically, 0.5 nm
Wavelength Stability	0.05 nm/K
Sensitivity @650nm	>19E10 ¹⁵ cts*nm/Ws
Dark Noise	< 10cts (16-bit ADC)
Detector array	S-CMOS; 512 pixels (14µm pixel width)
Electronics	16 bits; connector: USB Alternatively, 8 pol. Extension port (5V ext. pwr.; UART; Trig.; Reset)

Product Information

Fiber connector	SMA 905, IS-02 (customizable on demand)
Dimension (w/o PCB)	Length: 60 mm; width: 35.3 mm; height: 8.3 mm
Operating temperature	0 °C to +40° C
Storage temperature	-40°C to +60° C

D. Communication interfaces

- USB
- UART (The protocol settings are 8N1 (1 start-bit, 8 bit, no parity, 1 stop-bit) and no handshake). Default baud rate is 115200.
- For more details about communication interfaces, please refer our hardware description for SDCM4.

UART user signals

Pin	Name	Signal	Value	Min	Typ	Max	Unit
1	V _{ext}	Power-IN	Voltage	4	5	5.25	V
			Current	40 (Sleep mode)	100-150	1200	mA
2	TRIG	Input	High	2.2		5.5	V
			Low	0		0.5	V
3	GPIO6/Temp	I/O	High	2.2		3.6	V
			Low	-0.3		0.5	
			Current			15	mA
4	U1RX	Input	High	2.2		3.6	
			Low	-0.3		0.5	V
5	U1TX	Output	High	2.2		3.3	
			Low	0		0.5	
			Current			10	mA
6	MRES#	Input	High	2.2		5.5	
			Low	0		0.5	V
7	GPIO0	I/O	High	2.2		3.6	V
			Low	-0.3		0.5	
			Current			15	mA
8	GND	GND					
9	GND	GND					
10	SHUT/LAMP		High	2.2		3.3	
			Low	0		0.5	
			Current			15	mA
11	GPIO7		High	2.2		3.6	V
			Low	-0.3		0.5	V
			Current			10	mA
12	VPower		Voltage	4	5	5.3	V

Product Information

		Power out	Current			300	mA
13	AN0	Analog-IN	ADC-Range	0		3.3	V
			Max. V	-0.3		3.6	V
14	3.3V	Power out	Voltage	3.1	3.3	3.4	V
			Current			100	mA

Signal Description

Pin	Name	Description
1	V _{ext}	External 5 V power supply input. Voltage between 4.2 V and 5.1 V is allowed with a max current of 1200 mA.
2	Trig	Trigger input with programmable active slope and internal pull up. Should be debounced. Please refer to “Specfirm Firmware Operation Instructions” for more information about available trigger settings.
3	GPIO6/Temp	User programmable general-purpose-input-output-pin. In standard operation mode this pin is used as analog input for temperature sensing together with onboard 10k NTC sensor.
4	U1RX	LV-TTL (3.3 V) UART serial communication input signal RXD. communication protocol is start bit, 8 bit data, no parity, 1 stop bit (8N1), no handshake. The standard baud rate is 115200 and can be set by the baud rate parameter.
5	U1TX	LV-TTL (3.3 V) UART serial communication output signal TXD. Communication protocol is start bit, 8 bit data, no parity, 1 stop bit (8N1), no handshake. The standard baud rate is 115200 and can be set by the baud rate parameter.
6	MRES#	Master Reset input, active low, internally pulled up to 3.3 V via 10 kΩ resistor. This pin can be used to perform a MCU-restart. Leave unconnected, if not used.
7	GPIO0	User programmable general-purpose-input-output-pin.
8	GND	
9	GND	
10	SHUT/LAMP	LV-TTL shutter/lamp output. Can be used to control external light source or shutter. This signals polarity is programmable by the lamppol parameter (0/1). It will be active before integration time of the line array begins until its end. The scan delay parameter can be used to define the amount of additional time to realize shutter operation or lamp stabilization before integration begins in light- or dark-scans. In case of using a flash lamp, the shut/lamp signal can be used for triggering. Flash lamp burst mode (several flashes in programmable intervals and pulse length) can be also controlled by this signal.
11	GPIO7	User programmable general-purpose-input-output-pin.
12	VPower	Current limited 5V Power Output. The voltage on that pin depends directly on the active power supply (USB or external) and should not be used as reference voltage.

Product Information

13	AN0	General purpose analog input pin for sensing applications.
14	3.3V	Regulated 3.3 V output, internally used for MCU and other digital circuits.

E. Power supply

Power Supply via USB or 5 V external.

Maximum power consumption: 4.7-5.25V, 400mA.

