



APPLIED SCIENTIFIC
INSTRUMENTATION



We Create Solutions

2019 PRODUCT CATALOG

Complete Imaging Systems | Modular Microscopes | Microscope Stages | Complete System Solutions



APPLIED SCIENTIFIC
INSTRUMENTATION

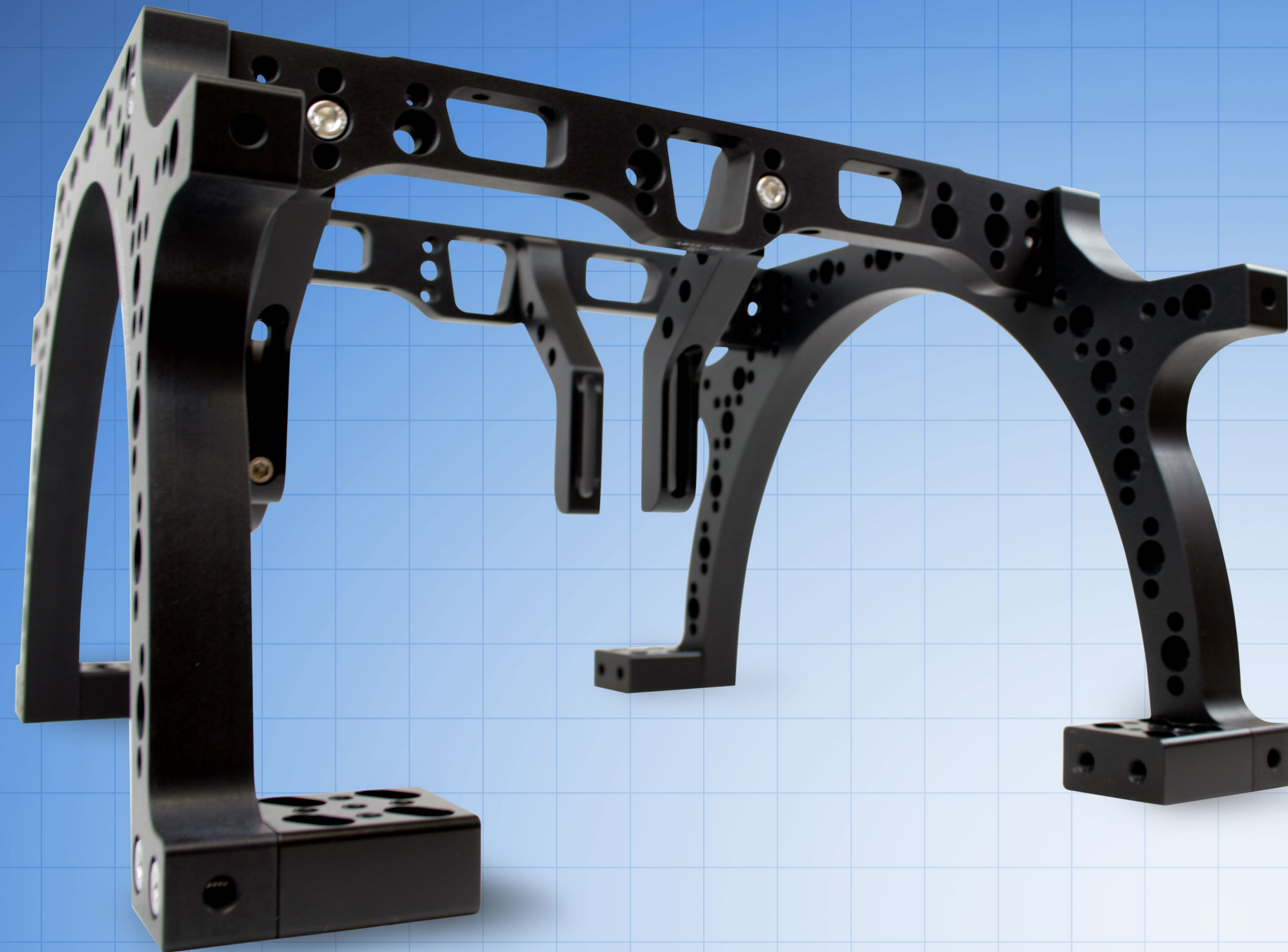

Table of Contents

Applied Scientific Instrumentation Products

Introduction to Applied Scientific Instrumentation	6
Ordering and Warranty Information	7
Partnership	8
Light Sheet Microscopy	
Dual Inverted Selective Plane Illumination Microscope (diSPIM) Parts and Assembly	10
Dual Selective Plane Illumination Microscope for Cleared Tissue (ct-dSPIM) Parts and Assembly	12
Oblique Single Plane Illumination Microscope (oSPIM) Parts and Assembly	14
Cleared Tissue Objective	15
Fiber-Coupled Laser Scanner	16
Rapid Automated Modular Microscope System	
Introduction	17
RAMM Configuration	18
Basic Components	19
Modular Infinity Microscope	
Introduction	22
System Kits	24
Tunable Lens	27
Tubes and Tube Components	29
Cage Adaptors and Components	33
Focus Side Components	35
Beamsplitter	36
Cube Components	38
Camera Mounts	40

Illumination Components	42
Objective Threads and Components	44
Coupling Rings and Ring Adapters	45
Versatile Test Stand	
Introduction	50
Test Stand and System Components	51
Microscope Support System and Components	52
Controllers	
Tiger Controller	50
Multi-Axis Stage Controller	51
Rack Mount Stage Controller	52
Z-Axis Drive and Controller	54
Piezo Z-Axis Stages	
PZ-2000 Series Stage	56
PZ-2000FT Series Stage	58
IPZ-3000 Series Piezo Insert and Sample Holders	60
PZM-2000 OEM Manual Stage	62
PZMU-2000 Piezo-Z Top Plate	64
PZU-2000 Series Stage	65
Compact Stages	
3D/4D Stage	68
Inverted Stages	
MS-2000 Flat-Top Stage	70
MS-2000 XY Stage	72
MS-2500-Ti Stage	74

Table of Contents

Applied Scientific Instrumentation Products

MS-2500-Dmi8 XY Flat-top Extended Travel Stage	76
MS-2500-AV XY Flat-top Extended Travel Stage	78
US-2000 Stage	80
Large Stages	
Introduction	82
MS-8000 Stage	83
XYZ Gantry Translation Stage	84
Linear Stages	
LS-Series Stages	86
Manual Stages	
MIC-2500 Manual Stage	88
Rotary and Translation Stages	
PRS-1000 Stage	89
FTP-2000 Stage	90
Upright Stages	
MS-2000 Low Mass Stage	92
MS-2000 Small Stage	93
OE-1250 Stable OEM System	94
MS-4400 XY Automated Stage	96
MS-9500 Stage	97
Z-Drives	
SZ-2000 Stereoscopic Zoom Microscope	98
Focus, Tracking and Stabilization	
CRISP Autofocus System	100
DCMS	102
PhotoTrack	103

XYZ Tracker	104
Video Autofocus Options	106
Fast Piezo Objective Mover	107
Illumination Control	
LED Lamp Illuminator and Drives	108
High Speed Filter Wheels	110
Photomultipliers and Detectors	
PMT - 200 Photomultiplier	112
Manipulation and Injection	
Pressure Injector	115
Micromanipulators	117
Motorized Actuator	120
Stage Wings	121
Stage Inserts	
Flat Plate Inserts	122
Petri Dish and Flask Inserts	123
Sealed Glass Chamber Inserts	126
Silver Finger Inserts	127
Special Item Inserts	128
160 x 110 mm Inserts	132
257 x 231 mm Inserts	136
283 x 110 mm Inserts	137

Applied Scientific Instrumentation

We Create Solutions.

Applied Scientific Instrumentation, Inc. (ASI) is a company committed to the advancement of science. Our engineers and technicians have years of experience in aiding researchers with their technical needs and our product line of devices for microscope automation and imaging represents the best technology available.

Established in 1990, our product line has evolved out of an interactive process between our engineers and the dedicated researchers who we work with throughout the world. Our products have been thoroughly tested and evaluated in numerous labs worldwide to insure the integrity of your research.

We are constantly improving our products as well as identifying and developing new designs to meet the current and future demand of scientific studies. We value your input to this process and would like to hear about any special requirements, feedback, or technical problems that we could help solve.

Whether it is a complete system for a complex experiment, automation devices for increasing throughput, or inspection systems to catch defects and increase production, Applied Scientific Instrumentation, Inc. has the products, professionals, and partners to provide well-engineered solutions for you.



Applied Scientific Instrumentation

Ordering Information

To order any of the products found in this catalog, or if you have any questions about our products and parts, please contact ASI at:

Phone: (541) 461-8181
Toll Free US/Canada: (800) 706-2284
FAX: 1-541-461-4018

ASI accepts payment via checks, ACH and wire transfer. We also accept payments from Visa®, MasterCard® and American Express.®



Product Warranties

Five Year Warranty for Stages

Applied Scientific Instrumentation, Inc., (referred to as ASI), guarantees its automated XY stages and control electronics against all defects in materials and workmanship to the original purchaser for a period of five (5) years from the date of shipment. ASI's responsibility to this warranty shall not arise until the buyer returns the defective product, freight

prepaid, to ASI's facility. After the product is returned, ASI at its option, will replace or repair free of charge any defective component or device that it has manufactured. The warranty set forth above does not extend to damaged equipment resulting from alteration, misuse, negligence, abuse, or as outlined below:

- 1.) Equipment not manufactured by ASI that is offered as part of complete system carries the original equipment manufacturer's warranty.
- 2.) The PZ-2150, PZ-2300, PZ-2500 units manufactured by ASI have a one year warranty.
- 3.) The DC servomotors used in our automated stages have a three-year warranty for biological applications in routine research.
- 4.) The linear encoder option has a two-year warranty.
- 5.) Damage from corrosive materials such as saline solution or other extreme contamination within the bearings and lead-screw assemblies voids the warranty.

One Year Warranty for Other Products

ASI guarantees its equipment against all defects in materials and workmanship to the original purchaser for a period of one (1) year from the date of shipment. ASI's responsibility to this warranty shall not arise until the buyer returns the defective product, freight prepaid, to ASI's facility. After the product is returned, ASI at its option, will replace or repair free of charge any defective component or device that it has manufactured. The warranty set forth above does not extend to damaged equipment resulting from alteration, misuse, negligence, abuse or as outlined below:

- 1.) Equipment not manufactured by ASI that are offered as part of complete imaging systems carry the original equipment manufacturer's warranty.

THE WARRANTY AND REMEDIES SET FORTH ABOVE ARE IN LIEU OF ALL OTHER WARRANTIES. APPLIED SCIENTIFIC INSTRUMENTATION, INC. EXPRESSLY DISCLAIMS ALL OTHER WARRANTIES WHETHER EXPRESSED, IMPLIED OR STATUTORY, INCLUDING THE WARRANTIES OF MERCHANTABILITY AND FITNESS FOR A PARTICULAR PURPOSE AND AGAINST INFRINGEMENT.

In no event will ASI be liable for incidental or consequential damages, even if ASI has been advised of the possibility of such damages howsoever, arising out of the sale or use of the products described herein.

Catalog Accuracy

Every effort has been made to ensure the accuracy of this catalog; however, Applied Scientific Instrumentation will not take responsibility for any loss incurred through error or omission of information. Part numbers and prices are subject to change. If you have any questions please feel free to talk with one of our representatives about your needs.



Complete Imaging Systems

Partnered with ASI

ASI has partnered with leading imaging system providers to offer you the best choices. Instead of selling our hardware bundled with just one or two software packages, we work closely with a number of imaging partners who support our hardware. This allows us to offer our customers a wide range of solutions for their particular imaging application.

Since we have been in the imaging and photometry business for over a decade, we are happy to talk with you about your particular application and recommend a complete hardware / software package to meet your needs. We also encourage you to visit each of our imaging partners' web sites, as they are some of the finest imaging companies in the world.

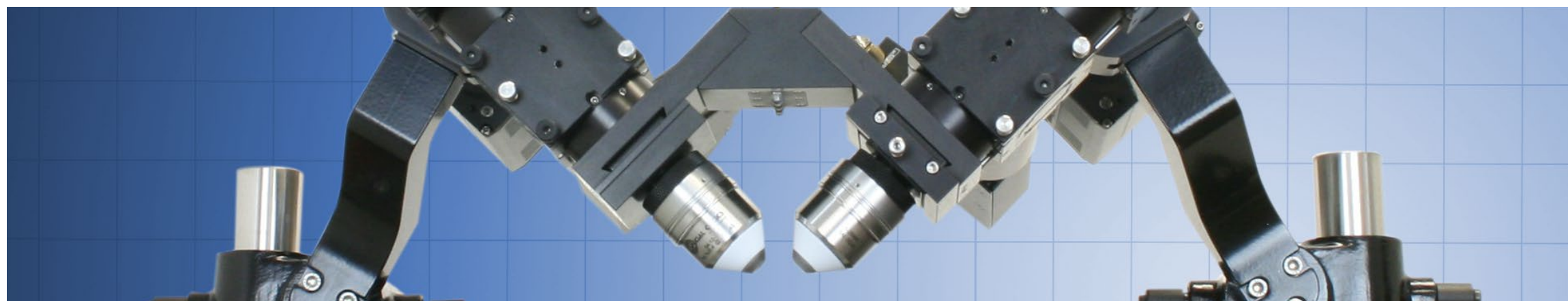

BIOQUANT

The BIOQUANT Automated Imaging Toolkit plug-in to BIOQUANT NOVA employs the ASI MS-2000-XY motorized stage and autofocus module to simplify diverse imaging tasks. The plug-in provides time-lapse imaging of multi-welled plates and culture dishes, high speed slide documentation, and efficient user controlled motion across a slide. The ASI MS-2000-XY stage is also used with the BIOQUANT Stereology Toolkit plug-in to BIOQUANT NOVA to provide superior closed-loop tracking of Z-axis position and dissector location. The ASI MS-2000-XY stage is tightly integrated with other BIOQUANT NOVA measurement features such as bone histomorphometry, cell counting, brain mapping, and 3D reconstruction.

www.bioquant.com

BioVision Technologies

Since 1995, BioVision Technologies has been dedicated to providing high quality imaging technologies. We specialize in the supply and integration of cutting edge equipment from world class manufacturers. We provide not just products, but solutions to complex problems that push the limits of light quantification. Our customers include microscopists, researchers, and Nobel laureates at leading universities, government agencies, and clinical labs.

Digital Pixel

Digital Pixel designs and manufactures complete systems for biomedical imaging. System configurations range from complete imaging suites including fluorescent microscopes, high resolution camera systems, heated environmental chambers, and computerised XY stages with digital autofocus, to a simple image capture system. At every level we take into account your future requirements in terms of applications and emerging technologies.

www.digitalpixel.co.uk

Improvisation

Improvisation is an international, market-leading company with an established reputation for the design and development of award winning, cross-platform software systems for scientific imaging. The Improvisation product range includes: Volocity – a highly innovative system for visualization, publication, and measurement of time-resolved multi-color 3D volumes, Openlab – modular software for cell imaging applications including deconvolution, ratio imaging,

3D rendering and morphological analysis, and Phylum – for capture, archiving, management, publication, and presentation of digital images. Improvisation takes pride in the development of easy to use, quality solutions, with market leading innovation.

www.improvision.com

Intelligent Imaging Innovations

Intelligent Imaging Innovations, Inc is a leading producer of 3D and live cell digital microscopy systems. I3 provides turn-key solutions built around fully automated fluorescence microscopes, retrofits for most older microscopes, and SlideBook™ software for both MacOS and Windows 2000/NT/98. SlideBook™ supports deconvolution, ratio imaging, 3D rendering, and advanced analysis.

www.intelligent-imaging.com

Life Science Imaging LTD

Life Science Imaging Ltd. designs and supplies complete systems for a wide range of live-cell and biomedical imaging applications. Configurations range from simple camera / software to complete imaging systems including microscope, X-Y stage with high resolution Z-drive and autofocus, environmental chamber, anti-vibration table, filter wheels and illumination sources (including LED), a wide variety of optical filters, high performance CCD cameras and MetaMorph software. Each system is individually configured to be flexible enough to cope with a wide range of both current and future applications. Individual components are also available as add-ons to existing systems.

www.lifescienceimaging.co.uk

Media Cybernetics

Media Cybernetics produces imaging solutions for researchers who must capture, manage, extract, analyze, share, and display image data. Reflecting over 20 years of development, evolution, and user feedback, our Image-Pro Plus image analysis software includes extensive enhancement and measurement tools. Image-Pro Plus also offers advanced microscopy plug-in modules including Scope-Pro for automated stage control, AFA for Advanced Fluorescence Acquisition, SharpStack for image deconvolution, and 3D Constructor for three-dimensional image rendering and measurement. In addition to our Image-Pro products, our QED Imaging product line provides cross-platform digital imaging solutions for a range of life science applications.

www.mediacy.com

Complete Imaging Systems

Partnered with ASI

Micro-Manager

µManager is an Open Source software package for imaging and control of automated microscopes on multiple platforms (Windows, Mac, and Linux). Together with ImageJ, a popular image processing package, µManager provides a comprehensive and highly extensible imaging solution. In addition, Micro-Manager can be used from environments like Matlab. Micro-Manager has extensive support for ASI stages, filter wheels, shutters, CRISP and other peripherals. See the Micro-Manager Wiki for details on device support. The µManager software, including device drivers, is free.

www.micro-manager.org

Objective Imaging

Objective Imaging's Surveyor automated scanning and imaging software with Turboscan for real-time mosaic imaging enables scanning and near perfect-image mosaic creation at camera frame rates. Based on the OASIS-4i controller with either the OASIS-DC1 digital camera interface or OASIS-AF analog video processor option, Surveyor with Turboscan provides everything a microscopist needs for surveying, relocating, printing and saving at a new standard in high-performance automation.

www.objectiveimaging.com

Stereology Resource Center

Stereology is a stochastic geometry and probability theory-based method for estimating quantities such as total neuron number in a mouse hippocampus, or the length of fibers. Other parameters that can be estimated include volume, area fraction, and surface area of cells and regions of interest. Stereology differs from image analysis in that the technician must perform some work identifying cells of interest instead of programming a computer to do the analysis. Therefore, a large and growing demand continues to exist within the biomedical research community for computerized systems that support accurate, efficient, and user-friendly stereological analyses of biological tissue. STEREOLOGER integrates the MS-2000-XYZ motorized stage and focus drive for efficient, seamless data collection. The MS-2000-XYZ provides the Z accuracy and closed-loop control necessary for proper stereological use.

www.disector.com

Universal Imaging

Universal Imaging Corporation, now part of Molecular Devices, was established in 1983 with the goal of developing powerful and affordable imaging solutions for scientists and researchers. Today, the MetaMorph and MetaFluor imaging systems demonstrate their continued commitment to that goal. Both MetaMorph and MetaFluor provide advanced full featured device control of many of ASI's peripheral devices for microscopy such as filter wheels, stages, z-axis focus motors, shutters, and monochrometers.

www.moleculardevices.com

VisiTech International

VisiTech International's aim is to provide innovative confocal imaging technology to the life and material science communities. We specialize in providing both multi-point and single-point confocal scanners that suit a wide range of scientific requirements. VisiTech International also provides full microscopy system solutions. VisiTech's patented VT-Infinity multi-point 2D-array scanning (with selectable pinhole sizes) and VT-Eye ultra fast single-point scanning confocal technologies offer unique benefits for the study of dynamic phenomena, including field-of-view selection and rapid collection of image Z-stacks using motorized microscope stages with piezo focusing.

www.visitech.co.uk

VISITRON Systems

VISITRON Systems GmbH acts as a System House for distribution and system integration in the market of Microscopy and Digital Image Processing. Our powerful Imaging Software controls the complex automation of your experiments, resulting in maximum data throughput with powerful data analysis. We support easy-to-use time-lapse experiments with full control of all automated microscopes and various peripherals. The processing spans from correction and manual measurements up to complicated morphometric analysis with automated spreadsheet reports. These features let our systems be perfectly suitable for modern microscope applications in Biology and Medicine.

www.visitron.de

Light Sheet Microscopy

Dual Inverted Selective Plane Illumination Microscope

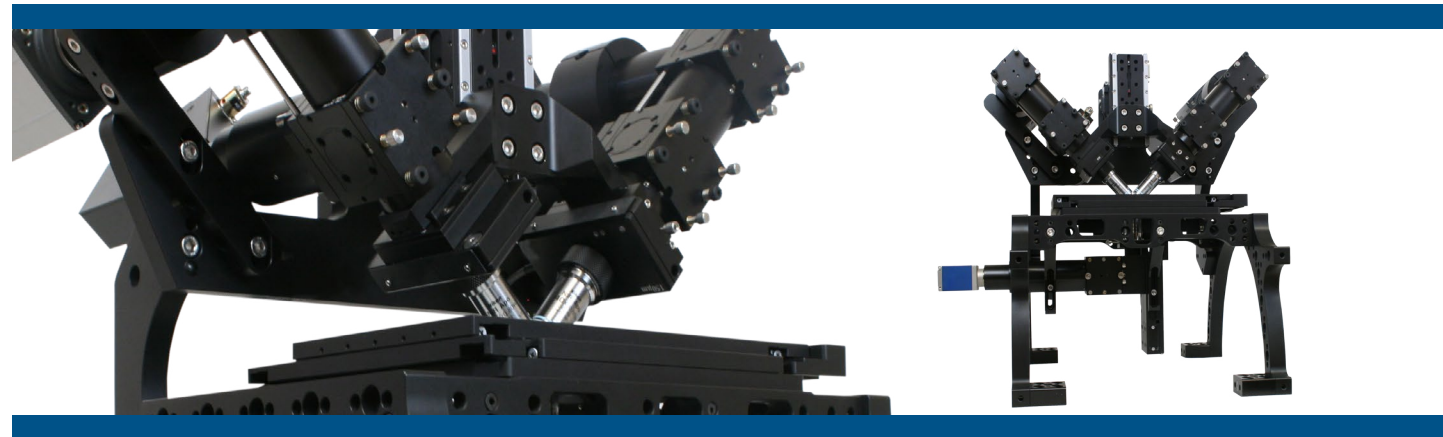

ASI offers all of the necessary hardware to implement the diSPIM, which is a flexible and easy-to-use implementation of Selective Plane Illumination Microscopy (SPIM) that allows for dual views (d) of the sample while mounted on an inverted (i) microscope. The diSPIM “head” can be mounted on various inverted microscopes including ASI’s RAMM frame.

ASI manufactures the optomechanical elements, including the motorized stages, 2D galvos for creating and moving the light sheet, and the piezo objective movers. Objectives, lasers, and cameras are required to complete the system; users can procure these other items themselves, use the services of various system integrators selling the diSPIM, or purchase them via ASI.

The diSPIM has been tested successfully on cells cultured on cover slips, cells embedded on collagen gels, c. elegans and zebrafish embryos, and many other samples.

Features

- Low photobleaching >10x reduction vs. confocal/spinning disk
- Rapid 3D imaging with isotropic resolution
- ~2x better axial resolution than confocal/ spinning disk
- Acquisition rates up to 200 planes per second
- Conventional sample mounting on coverslip or open dish
- Modular and flexible

More Information

You may find more detailed information at dispim.org or asiimaging.com.

Specifications

Field of View*	>400 μm diagonal
Resolution*	380 nm @ 500 nm wavelength in XYZ
Sample Size*	Large flat samples up to 200 mm thick, or up to 3.5 mm radius hemisphere

*Depends on objective, these are for Nikon 40x/0.8 WD.

Mounting	Cover slip or open dish
Imaging Depth	Limited by scattering, usually 50 -200 μm depending on sample
Software	Various free/open-source and proprietary
Photomanipulation	Available using inverted microscope objective
Incubation	25-40 °C with CO ₂ and humidity control (others possible)
Compatible Cameras	Any sCMOS with external trigger
Compatible Lasers	Any with TTL control (dual fiber output beneficial)
Acquisition Modes	Synchronized slice/piezo Stage scan Fixed sheet
Multi-D Acquisition	Any combination of: Time Points Multi-position Multi-color (up to 4)

Light Sheet Microscopy

Dual Inverted Selective Plane Illumination Microscope

Basic System Configurations

1) Single-Sided System (iSPIM): Light sheet created from one objective and imaged using the other objective. The light sheet is moved through the sample, most often by moving the light sheet using the scanner (galvo) which is synchronized with a piezo stage moving the imaging objective.

Advantages: Fastest acquisition, least expensive, straight-forward set-up

Disadvantages: Better XY resolution than Z resolution

2) Dual-Sided System (diSPIM): Both sides have a light sheet scanner, piezo objective positioner, and camera. During an experiment a stack of images is collected from both views, and the two datasets can be merged computationally to yield a 3D dataset with isotropic resolution (the usual problem of poor axial resolution is overcome by information from the other view). Can operate in single-sided mode if desired.

Advantages: XY and Z resolutions are all very good – yielding a combination of speed and resolution that is unsurpassed for live cell imaging.

Disadvantages: More hardware to buy. Data post-processing required for isotropic resolution.

Example Variations:

- Photomanipulation using inverted microscope
- Filter wheels on imaging paths
- Asymmetric single-sided system, e.g. using same objectives as Lattice Light Sheet
- Non-gaussian beam
- 2-photon microscopy

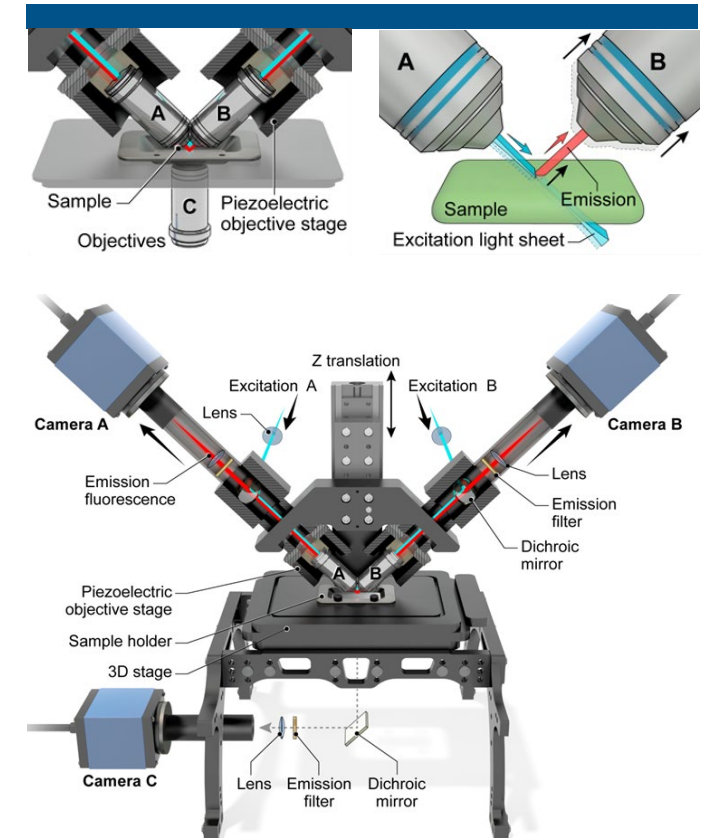

diSPIM Concept

Two immersion objectives (A/B) are placed at right angles above a sample mounted horizontally in an open dish, each objective 45° from vertical. A light sheet is created from objective A and imaged using objective B onto camera B. By moving the light sheet through the sample a stack of images is acquired, most often by moving the light sheet with galvo mirrors (not shown) synchronously with the imaging objective via a piezo stage. For some applications, the 3D information from a single view or stack is sufficient (iSPIM). For dual-view systems (diSPIM), the role of the two objectives is reversed to collect another stack from a perpendicular direction; although excitation and detection are shown schematically simultaneously, they are actually sequential. The two datasets can be computationally merged to yield a 3D dataset with isotropic resolution, and the usual problem of poor axial resolution is overcome by information from the other view. The sample may also be viewed through objective C, which belongs to an inverted microscope (either from ASI or from another microscope vendor). Objective C can be also used for photomanipulation, even during the light sheet acquisition.

Contact ASI for assistance with configuration of diSPIM microscope.

Light Sheet Microscopy

Dual Selective Plane Illumination Microscope for Cleared Tissue



The ct-dSPIM is a flexible and easy-to-use implementation of Selective Plane Illumination Microscopy (SPIM) that allows for dual views (d) of large samples such as cleared tissue (ct).

The ct-dSPIM is one of many light sheet microscope configurations possible using ASI's modular components. We manufacture the optomechanical elements, including the motorized stages and 2D galvos for creating and moving the light sheet. ASI partnered with Special Optics to develop an objective optimized for light sheet imaging of cleared tissue. Lasers and sCMOS cameras are required to complete the system; users can procure these themselves, use the services of various system integrators selling ASI SPIM systems, or purchase them via ASI.

The ct-dSPIM has been successfully used to image various cleared tissue samples including whole mouse brains and slices of cleared tissue.

Features

- Image acquisition $>10^8$ voxels/sec
- Sub-micron resolution in XYZ (sample-permitting)
- Sample mounting in open dish
- Image >5 mm deep into flat samples or up to 12 mm radius sphere
- Media RI range from 1.33 to 1.56, aqueous or organic media
- Modular and flexible setup

Specifications

Field of View*	>1.1 mm diagonal
Resolution*	<800 nm @ 500 nm wavelength in XYZ if diffraction limited
Sample Size*	5 mm thick up to 200 mm in XY, or up to 12 mm radius sphere
<i>* Depends on objective, these are for ASI/Special Optics 16.7x/0.4 multi-immersion</i>	
Mounting	Open dish with objectives immersed in media
Imaging Depth	>5 mm into flat samples (aberrations often limit)
Software	Various free/open-source and proprietary such as Micro-Manager and 3i SlideBook
Photomanipulation	Available using inverted microscope objective
Compatible Cameras	Any sCMOS with external trigger
Compatible Lasers	Any with TTL control (dual fiber output beneficial)
Acquisition Modes	Stage scan recommended for large samples
Multi-D Acquisition	Any combination of: Multi-position Multi-color Time Points

Light Sheet Microscopy

Dual Selective Plane Illumination Microscope for Cleared Tissue

Basic System Configurations

1) Single-Sided System (iSPIM): Light sheet created from one objective and imaged using the other objective.

Advantages: Fastest acquisition, least expensive.

Disadvantages: Better XY resolution than Z resolution.

2) Dual-Sided System (diSPIM): Both objectives have a light sheet scanner and camera. Data is collected from both views sequentially, and the two datasets can be merged computationally to yield a 3D dataset with isotropic resolution. Can operate in single-sided mode if desired.

Advantages: XY and Z resolutions are all very good.

Disadvantages: More hardware to buy. Isotropic resolution requires double the acquisition time plus data post-processing.

Example Variations:

- Filter wheels on imaging paths
- Asymmetric single-sided system, e.g. using other manufacturer's high-NA clearing objective lens
- Non-gaussian beam
- 2-photon microscopy

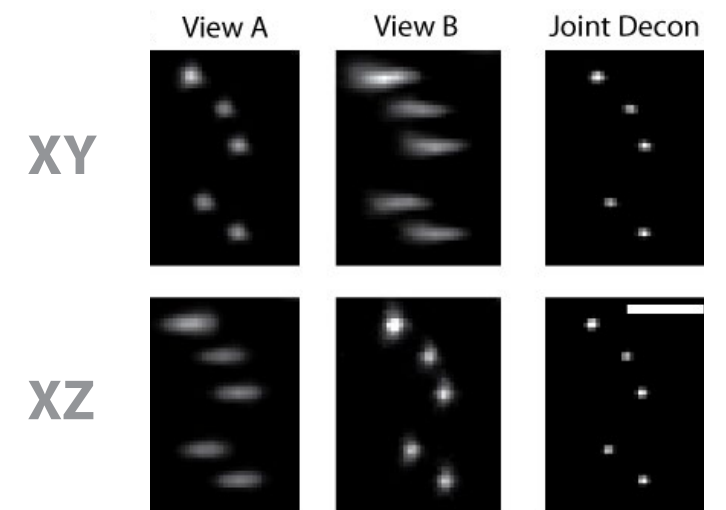
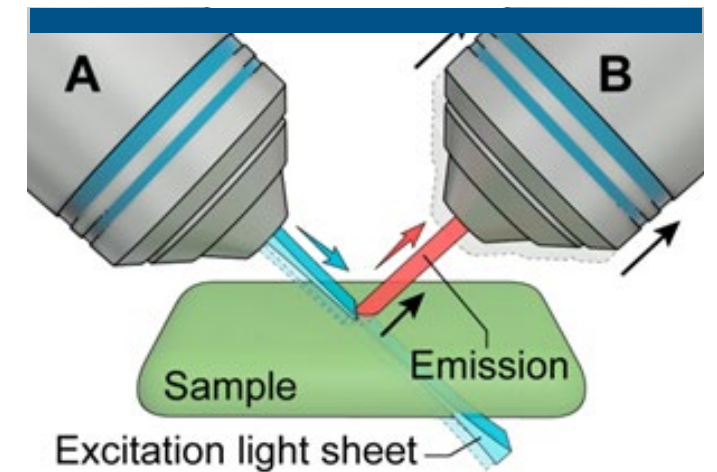

Joint Decon: A. York and Y. Wu

Wu et al. Nat. Biotechnol. 31, 1032-138 (2013), Kumar et al. Nature Protocols 9, 2555-2573 (2014), Ingaramo et al.

Dual-view SPIM Concept

Two objectives are placed at right angles above a sample mounted horizontally in an open dish, each objective 45° from vertical. A light sheet is created from one objective and imaged using the other objective. A stack of images is collected by moving the light sheet through the sample; in the case of ct-dSPIM, the sample is normally moved through a stationary light sheet using the XY stage. For some applications, the 3D information from a single view or stack is sufficient. For dual-view systems, the role of the two objectives is reversed to collect another stack from a perpendicular direction. The two datasets can be computationally merged to yield a 3D dataset with isotropic resolution; the usual problem of poor axial resolution is overcome by information from the other view.

Contact ASI for assistance with configuration of an dSPIM microscope.

Light Sheet Microscopy

Oblique Single Plane Illumination Microscope



ASI's oSPIM is an excellent platform for imaging live cells or other samples on a coverslip using fast and gentle light sheet microscopy. The oSPIM is a single-view light sheet system where the light sheet is generated at an oblique angle using an oil immersion objective below the sample dish. Fluorescent emission is observed using a high NA water dipping objective from the top, with the objective tilted 60 degrees, perpendicular to the illumination sheet. The arrangement with high NA objectives both above and below the sample dish allow for high-resolution imaging in a convenient geometry for cell culture work.

The oSPIM is two microscopes in one. The lower microscope can be used for fluorescent imaging using conventional modalities, such as wide field fluorescence, confocal, or TIRF. It is also utilized as the light sheet excitation objective. The tilted top microscope is dedicated to light sheet images.

Features

- Low photobleaching >10 x reduction vs. confocal/spinning disk
- Water dipping emission objective yields 280 nm transverse resolution (NA up to 1.1)
- Rapid 3D imaging at oblique angle to coverslip, up to 200 planes per second
- Conventional sample mounting in cell culture dishes
- Fully functional "conventional" fluorescent microscope in addition to the light sheet modality
- Modular and flexible

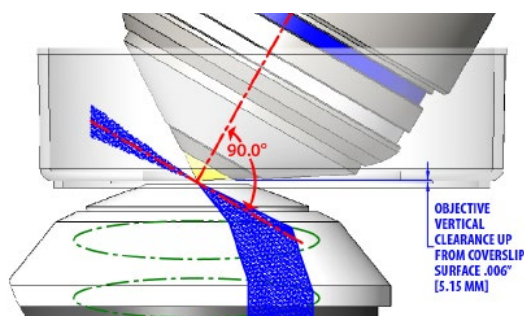

Specifications

Field of View*	>250 μm diagonal
Resolution*	280 nm XY, ~670 nm Z @ 500 nm wavelength
Sample Size*	Best for thin transparent samples such as cells or tissue cultures mounted on coverslips
<i>* Depends on objective and camera; these are for 60x NA 1.1 and sCMOS camera.</i>	
Mounting	35 mm \varnothing or larger glass-bottom dish, cover slip
Imaging Depth	Limited by scattering, usually 30 -150 μm depending on sample
Software	Various free/open-source and proprietary
Photomanipulation	Available using inverted microscope objective
Incubation	25-40 $^{\circ}\text{C}$ with CO ₂ and humidity control (others possible)
Compatible Cameras	Any sCMOS with external trigger
Compatible Lasers	Any with TTL control
Acquisition Modes	Synchronized slice/piezo Stage scan Fixed sheet
Multi-D Acquisition	Any combination of: Time Points Multi-position Multi-color (up to 4)

Contact ASI for assistance with configuration of an oSPIM microscope.

Light Sheet Microscopy

Cleared Tissue Objective

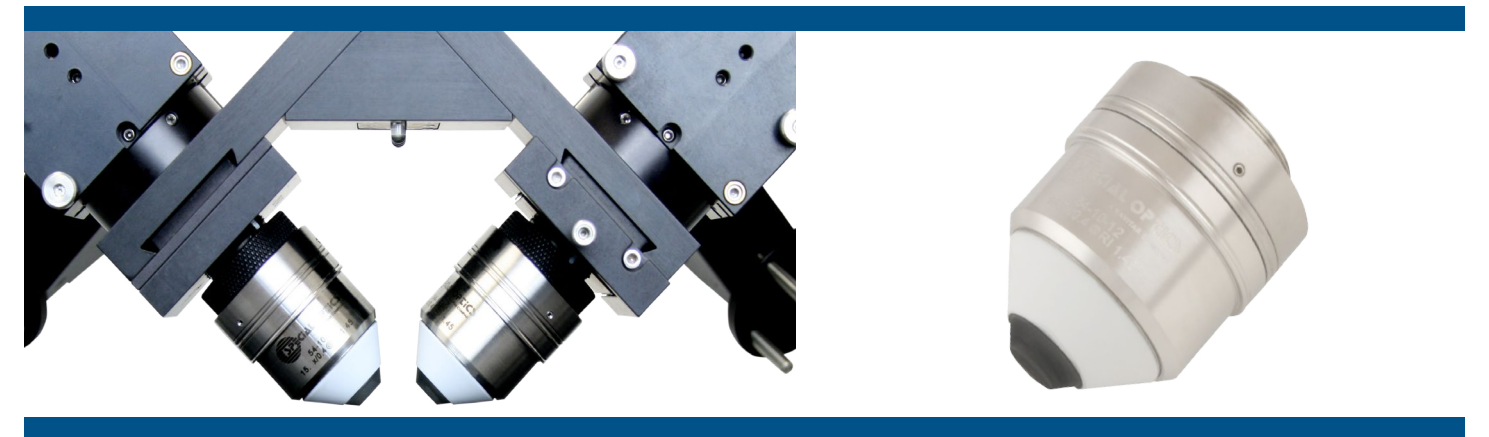

ASI and Special Optics have developed an immersion objective lens specifically designed for light sheet microscopy of cleared tissue samples, including ASI's dual-view Selective Plane Illumination Microscopy (dSPIM), which enables isotropic resolution without manipulating the sample. The lens is also appealing to researchers building customized microscope setups (e.g. OpenSPIM type) because it is available for separate purchase unlike other objectives suitable for cleared tissue.

The 0.4 N.A. multi-immersion objective is designed for dipping media RI ranging from 1.33 to 1.56, >1 mm field of view, ~17x magnification, and 12 mm working distance. When used in multi-view systems like the diSPIM, the cleared tissue objective offers sub-micron resolution in X, Y, and Z.

The large working distance enables imaging samples that were previously inaccessible. The objective permits imaging more than 5 mm deep into a flat sample when rotated at a 45 $^{\circ}$ angle above the sample, as used in the diSPIM.

Applications

- Dual-view cleared tissue imaging (diSPIM with cleared tissues)
- Single-view cleared tissue imaging (OpenSPIM setups for cleared tissues)
- Water-dipping applications with very long working distances

Specifications

Specifications	Value	Comments
Numerical Aperture	0.4 @ RI 1.45	0.37 – 0.43 over RI range
Immersion Media RI	1.33 – 1.56	Includes all major clearing solutions
Effective Focal Length	12 mm @ RI 1.45	15.3 x – 17.9 x over RI range w/ 200 mm TL
Working Distance	12 mm (for all RI)	5.1 mm imaging depth with flat sample, 12 mm \varnothing sphere
Field of View	1.2 mm \varnothing	
Spherical Correction	480 – 1000 nm	Diffraction-limited for most media and λ
Chromatic Correction	480 – 720 nm	Performance varies by media, optimized for CLARITY and TDE
Correction Collar	None	Designed for immersion w/o coverslip
Form Factor	Nikon style	61.6 mm parfocal distance, M25 threads, 40 mm OD



Fiber-Coupled MEMS-Mirror Laser Scanners

Fiber-Coupled Laser Scanners

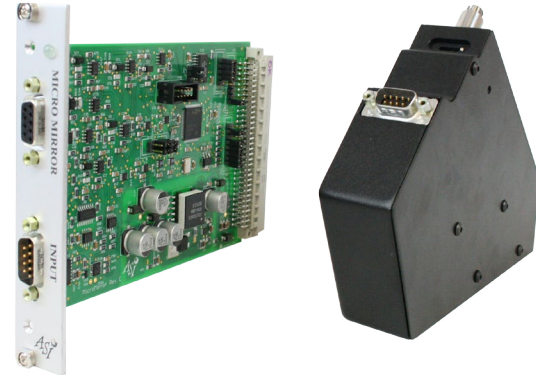

ASI's 2D Fiber-Coupled Laser Scanners are compact and versatile units originally designed for generating SPIM light sheets. A user-provided light beam enters the scanner on a standard fiber optic connector. The beam is steered in the sample plane using an electronically-controlled galvo comprising an integrated two-axis MEMS mirror devices, providing rapid response and negligible vibration across the full field of the microscope sample. An optional anti-stripping mirror varies the beam's angle of incidence on the sample to mitigate shadowing effects. Adjusting the included iris changes the light sheet thickness and depth of focus. The beam can be effectively turned off or "blanked" by simply steering the beam to one corner. The scanner is interfaced to the microscope using any C-Mount port.

Applications

- Light Sheet Microscopy
- Optogenetics
- Local Uncaging
- FRAP

Specifications

Light Input	FC/PC fiber optic connector (optically FC/APC)
Scanner Operating Frequency	Approximately 1 kHz (>200 Hz sheet rate)
Scan Range	16 mm Ø field of view (at C-Mount focus)
Beam Blanking	<0.1% Transmission
Max Input Power	>500 mW
Control Electronics	TG-1000 Micro mirror drive card required (uses internal control or external analog inputs)
Anti-Striping	Available on request
Mechanical Coupling	C-Mount

Features

- C-Mount attachment and image plane
- Aperture control with iris and/or adjustable slit mask
- Scanner deflection beam blanking

C-Mount Gaussian Beam Scanner

C-Mount Gaussian Beam Scanner is an 2-axis focused beam scanner. The laser, a single mode fiber, is coupled with FC/APC or FC/PC collimator. It provides focused scan-plane at the female C-Mount. Uses with the TGMM4 controller.

- Collimator focal length: 7.5, 12.5, or 20 mm
- FC/PC or FC/APC

MM-SCAN_1.2 SLS1.2

C-Mount Cylindrical Lens Scanners

C-Mount Cylindrical Lens Scanners is a light sheet generator equipped with XY scan mirror and coupled to the light source with one FC/PC or FC/APC fiber optic cable. 1.2 mm or 2.4 mm scanner mirrors can be specified. A Focused light sheet is provided at the C-Mount focal plane.

MIM-CYL_1.2 SCS1.2
MIM-CYL_2.4 SCS2.4

Cube-MEMS-Mirror Scanner

Cube-MEMS-Mirror Scanner is a cube assembly with a 2.4 mm diameter XY scanning mirror. Use with the TGMM4 controller. Includes integrated two-axis MEMS-Mirror scanner and CUBE-III assembly. The C-60-TUBE_70D is the suggested scan lens to use with the Cube- MEMS-Mirror Scanner.

C60-MMSC-2.4 SCN2.4

Rapid Automated Modular Microscope

Modular Design for Rapid Automation Development

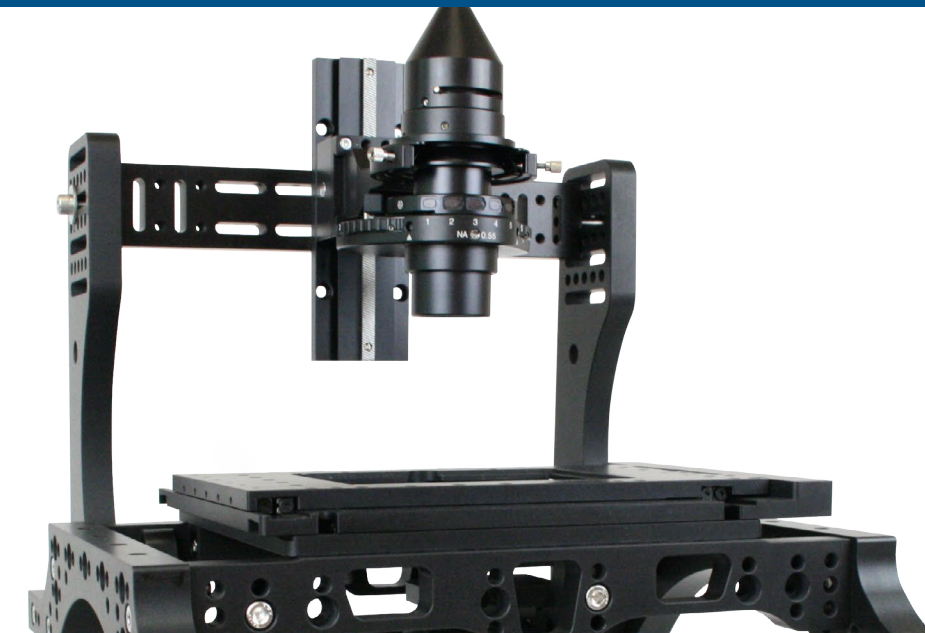

RAMM Features

- Automated high-speed XY stages, precision piezo and motorized Z focusing, and a wide range of scanning options
- Configurable with infinity-corrected optics, dichroic filter cubes, multi-wavelength excitation and emission filter wheels, shutters, and detectors including cameras and photomultipliers
- Autofocus, focus stabilization, and tracker available
- Arrangement provides a solid platform for high throughput screening, genetic sequencing, experimental research among others implementations
- Designed for flexible OEM development using high quality high, MTBF components to reduce cost and increase customer satisfaction

System Customization

ASI's RAMM system can be used with our MS-2000 Stages, FW-1000 Filter Wheels, and other items. Custom optical systems can be configured using ASI's Modular Infinity Microscope.

Specifications for Standard Configuration

XY stage range of travel	120 mm x 75 mm
Linear translation range of travel	At least 50 mm
Resolution (rotary encoder step)*	0.022 µm
RMS repeatability*	< 0.7 µm
Maximum velocity*	7 mm/sec

*Shown with 6.35 mm pitch Lead Screw

Lead Screw Options

Lead Screw Pitch Options	Rotary Encoder Resolution	Maximum Speed
25.40 mm (Ultra-coarse)	88 nm	28 mm/sec
12.70 mm (Super-coarse)	44 nm	14 mm/sec
6.35 mm (Standard)	22 nm	7 mm/sec
1.57 mm (Fine)	5.5 nm	1.75 mm/sec

Optional Linear Encoders: = 10 nm Resolution, Accuracy = ±3 µm per length of scale of 120 mm

Contact ASI for assistance to discuss your microscope needs.

Rapid Automated Modular Microscope

Basic, Full, and Dual Configurations



RAMM Basic Frame

Includes:

- 2 RAMM-B1001 Arches
- 4 RAMM Universal (RAMM-B1002) Feet
- 2 RAMM-B1066 Crossbars
- 1 MIM Tube Clamp Pair (RAMM-B1013)
- 4 RAMM-B1016 Vertical Supports

RAMM Full Frame

Includes:

- RAMM Basic
- 2 RAMM-B1008 and RAMM-B1008EX Risers
- 1 RAMM-B1007 Riser Crossbars

RAMM DUAL

Includes:

- RAMM Basic
- 2 RAMM-B1066 Crossbars Risers
- 4 RAMM-B1030 Vertical Mounting Bars
- 2 RAMM-B1007 Riser Crossbars
- 2 RAMM-B1016 Vertical Supports

Rapid Automated Modular Microscope

RAMM Basic Components



RAMM Arch

Typically two (2) required

RAMM-B1001



RAMM Crossbar

Top bar for stage mount with clearance for optics; typically two (2) required

RAMM-B1066



RAMM Vertical Supports

Used with B1017 Crossbar pair to support LS-50 or B1013; typically two (2) required

RAMM-B1016



RAMM Crossbar Riser Support

Used for mounting top-side components; used with 6" or 8" travel stages; typically two (2) are required

RAMM-B1008EX



RAMM Riser Crossbar

Fits between RAMM System risers for mounting top-side components

RAMM-B1007



RAMM Universal Foot

Allows mounting to either metric or English breadboards; typically four (4) required

RAMM-B1002



RAMM Vertical Tube Support

RAMM system vertical tube support bracket

RAMM-B1022

RAMM-B1021



RAMM Riser

Used for mounting top-side components; used with standard microscope stages and typically two (2) are required

RAMM-B1008

Rapid Automated Modular Microscope

RAMM Basic Components



RAMM Vertical Mounting Bar

Top vertical mounting bar for the RAMM system

RAMM-B1030



RAMM Vertical Mounting Bar

Extended top vertical mounting bar for the RAMM system

RAMM-B1030EX



XY Precision Centering Stage

Commonly used to center devices over microscope objective; 25 mm X travel, 8 mm Y travel, load capacity 25 kg, resolution~ 10 microns

CDZ-1000



Dovetail Mount Pairs

(VTS-2112 and CDZ-1010) 60 mm x 62 mm x 10 mm overall dimensions; each part mounts with four M6 Flat Head screws on 25 mm x 25 mm pattern

DV-6010

LS-DAE-M

LS-RADA

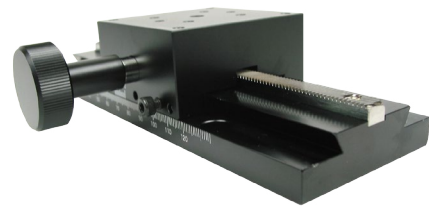

Z-Rack

Z-Rack and pinion positioner for manually focusing condenser; provides very precise positioning capabilities

Z-Rack



RAMM Stilts

Raise the RAMM system if more height is needed; typically four (4) required

RAMM-B1031



MIM Tube Clamp Pair

50mm inner diameter; used with RAMM for vertical supports

RAMM-B1013



RAMM CDZ Spacers

Standard stage spacers; typically four (4) required

RAMM-B1010

Modular Infinity Microscope

MIM System

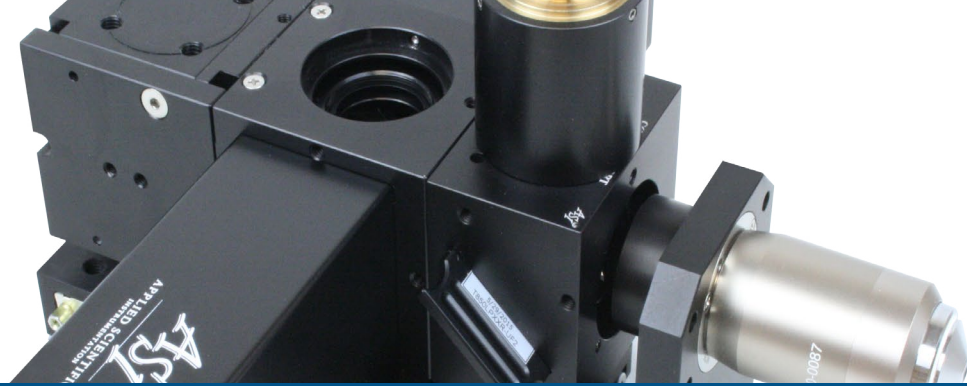

ASI's Modular Infinity Microscope components consist of tube lenses along with adapters and accessories that either are primarily used in the collimated light space or adapters that are to be used on the image side. Collimated light adapters use the 38 mm diameter C60-RING system to connect components. Focus-side adapters attached to lens tubes with either a 30 mm diameter coupling to the I.D. of the C60-TUBE, or with a 50 mm coupling on the O.D. of the lens tube.

With infinity microscope systems, the objective can be spaced away from the tube lens without changing the optical magnification. This "infinity space" provides a region where other optical systems can be coupled to the microscope relatively easily. For epi-fluorescent illumination, a filter cube with a dichroic beam splitter can be added to provide the illumination path.

The cube module accepts a standard Olympus U-MF2 filter cube and provides coupling to the objective, tube lens assembly, and a fiber illuminator optic.

The MIM system uses as standard 38 mm diameter coupling ring to attach standard modules together. Three or four set screws on each component lock to the coupling ring and provide a simple, accurate, and flexible method of assembly. Each coupling ring also provides a space to include a beam stop. Appropriately placed stops can significantly reduce scattered light in the system.

The minimum parts required to construct an infinity microscope system are the microscope objective, the tube lens, and a camera mount.

Basic Components

- Tube Lens Section – image forming section with 200 mm f.l. tube lens
- C-Mount – camera port.
- Infinity Space Beam Splitter Cube – can be used for Epi-fluorescence filter cube or as right-angle objective adapter
- Objective Adapter – options for Nikon CFI60, Mitutoyo, or Olympus RMS thread objectives
- Universal Coupling – used on all infinity-space components for design flexibility

Optional Components

- C-Mount Beam Splitter – provides a second camera/detector port
- Filter Wheel Adapter – use with ASI FW1000 filter wheel
- Motorized positioner – use ASI LS-50 stage to focus the microscope system
- Inverted or Upright test stand and ASI motorized stages

Modular Infinity Microscope

MIM System



Specifications

Tube Lens	Standard 32 mm dia. x 200 mm f.l. Nikon Also 100 mm, 120 mm, 160 mm, 300 mm and 400 mm f.l. achromat tube lenses are available.
Beam Splitter	Olympus AX/BX/IX series cube U-MF2
Objectives Supported	Nikon CFI60 Series Mitutoyo LWD Series Olympus ∞ corrected
Camera Port	C-Mount, T-Mount, F-Mount, ENG-Mount
Illumination	Liquid Light Guide Adapter, Lamp Adapters, LED Sources Available.
Configurations	Limitless

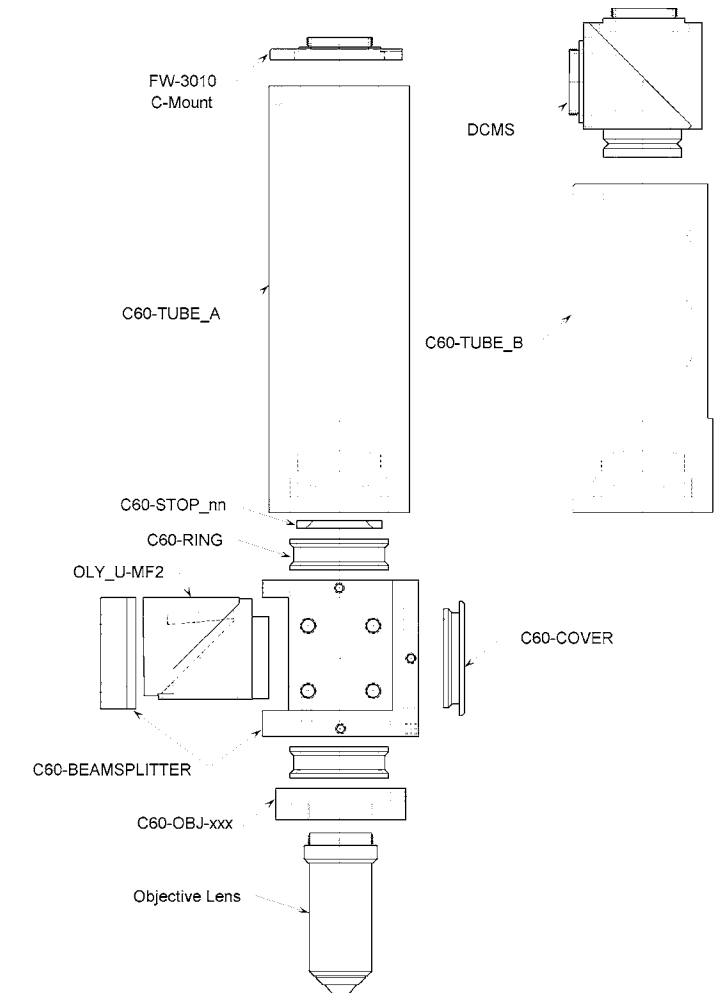

Modular Infinity Microscope

MIM System Kits

All the MIM systems kits listed below include a motorized focus using the ASI LS-50 actuator. The LS-50 also becomes the backbone of the microscope. These kits can be used for either upright or inverted microscope configuration.



BASIC SINGLE LAYER MIM CONFIGURATIONS

MIM1-OSxx: MIM basic backbone with automated focus and one horizontal imaging path. Provides >15 mm focus travel range. Contains C60-RA_MIRROR, C60-OBJ_xxx, C60-RING, LS-50 stage.

Example Systems built on the MIM1-OSxx

- **MIM1-OSRMS** – Basic MIM1 with RMS (Olympus) objective adapter.
- **MIM1-OSM25** – Basic MIM1 with M25 (Nikon) objective adapter.
- **MIM1-OSM25-PI** – MIM1 single objective microscope with C60-CUBE-I epi-fluorescent port (picture).
- **MIM1-OSM26-P11** – MIM1 single objective microscope with C60-CUBE-II epi-fluorescent port.
- **MIM1-OSM27-P11-TN200-MMC** – MIM1 single objective microscope with C60-CUBE-II epi-port and Nikon 200 mm tube lens and C-Mount adapter.



BASIC DOUBLE LAYER MIM CONFIGURATIONS

MIM2-OSxx: MIM basic backbone with automated focus and two horizontal imaging paths. Provides >15 mm focus travel. C60-RA_MIRROR, C60-OBJ_xxx, C60-RING, C60_RA_2nd_PORT, and LS-50 stage. This configuration is often used with the CRISP autofocus on the second layer.

Example Systems built on the MIM2-OSxx

- **MIM2-OSRMS** – Two-port MIM2 with RMS (Olympus) objective adapter.
- **MIM2-OSM25** – Two-port MIM2 with M25 (Nikon) objective adapter.
- **MIM2-OSM25-P11** – MIM2 single objective microscope with C60-CUBE-II epi-fluorescent port (picture).
- **MIM2-OSxx-P11-TN200-MMC** – MIM2 single objective microscope with C60-CUBE-II epi-port and Nikon 200mm tube lens and C-Mount adapter.

Modular Infinity Microscope

MIM System Kits



CUBE BASED MIM CONFIGURATIONS

MIM3-OSxxx: MIM basic backbone with automated focus for use with C60-CUBEs directly w/LS-50 stage. Provides >15 mm focus travel. DV6010 dovetail mount, C60-RA_OBJ_FC_MNT, C60-OBJ_xxx.

Example Systems built on the MIM3-OSxxx

- **MIM3-OSxxx-P11-TN200** – MIM3 single objective microscope with C60-CUBE-II for epi-fluorescent port and mirror port. Nikon tube lens included. Simple upright scope.
- **MIM3-OSM25-P11** – MIM3 single objective microscope with C60-CUBE for epi-fluorescent port (picture).
- **MIM3-OSxxx-2P11-TN200-MMC-CM25** – MIM3 single objective microscope with two C60-CUBE-IIs for epi-fluorescent port and mirror port w/mirror.

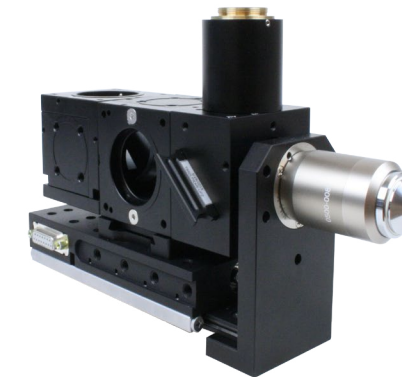

CUBE BASED WITH SHORT PORT MIM CONFIGURATIONS

MIM3-PSL-OSxxx: MIM basic backbone with automated focus for use with C60-CUBEs directly w/LS-50 stage. Provides >15 mm focus travel. DV6010 dovetail mount, C60-RA_OBJ_FC_MNT, C60-OBJ_xxx. Also includes top C60-SHORT_PORT_L (frequently used for CRISP coupling).

Example Systems built on the MIM3-PSL-OSxxx

- **MIM3-PSL-OSxxx-2P11-TN200-MMC-CM25** – Single objective microscope with C60_SHORT_PORT_L and two C60-CUBE-IIs for epi-fluorescent port and mirror port w/mirror.
- **MIM3-PSL-OSM25-P11-PI-MMC** – Single objective microscope with C60_SHORT_PORT_L and C60-CUBE-IIs port and C60-CUBE-I-mirror port with C-Mount on short epi port often for CRISP (picture).

Modular Infinity Microscope

MIM System Kits



CUBE_SLDR MIM CONFIGURATIONS

MIM4-OSxxx: MIM backbone with automated cube slider, automated focus w/LS-50 stage. Provides >15 mm focus travel. Includes C60-RA_OBJ_FC_MNT, C60-OBJ_XXX.

Example Systems built on the MIM4-OSxxx

- **MIM4-OSxxx-PI-TN200-MMC-CM25** – MIM4 single objective microscope with Cube Slider for epi-fluorescence and C60-CUBE-I mirror port w/mirror and 200 mm Nikon tube lens with C-Mount adapter.
- **MIM4-OO6A-PI-TN200-MMC-CM25** – MIM4 microscope with Cube Slider for epi-fluorescence and C60-CUBE-I w/mirror, automated Oly turret, and 200 mm Nikon tube lens with C-Mount adapter.
- **MIM4-OSM25-PI** – Single objective microscope with cube slider plus C60-CUBE-I mirror port (picture).

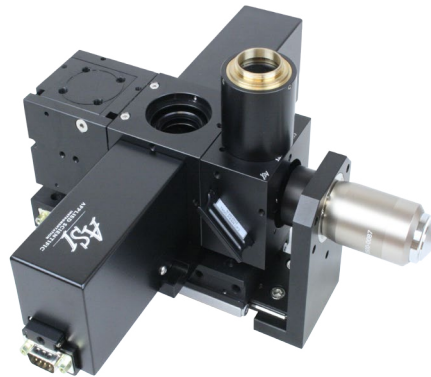

CUBE_SLDR WITH SHORT PORT MIM CONFIGURATIONS

MIM4-PSL-OSxxx: MIM backbone with automated cube slider, automated focus w/LS-50 stage. Provides >15 mm focus travel. Includes C60-RA_OBJ_FC_MNT, C60-OBJ_XXX, and short-port cube (w/lens) above slider.

Example Systems built on the MIM4-PSL-OSxxx

- **MIM4-PSL-OSxxx-PI-TN200-MMC-CM25** – Single objective microscope with Cube_SLDR for epi-fluorescence, C60_SHORT_PORT_L, C60-CUBE-I mirror port w/mirror, and Nikon tube lens C-Mount adapter.
- **MIM4-PSL-OSM25-PI-MMC** – Single objective microscope with Cube_SLDR for epi-fluorescence, C60_SHORT_PORT_L, C60-CUBE-I mirror port with C-Mount adapter on short port for CRISP.

Modular Infinity Microscope

Tunable Lens



About Tunable Lens

ASI's tunable lens is a versatile element for a variety of microscopy applications.

Tunable lenses can adjust the focal plane of a stationary microscope objective, replacing a focus stage. Using a bare tunable lens introduces significant optical aberrations, but combining the tunable lens with a 4f relay lens system reduces the aberrations to an acceptable level for many applications. ASI's 4f relay assembly with integrated tunable lens can be placed at the camera port of any microscope with a C-mount interface. ASI's XYZ Tracker uses a tunable lens in this manner to implement focus feedback on an auxiliary imaging path, allowing the tracker to automatically follow samples moving in Z.

Tunable lenses are commonly used in light sheet microscopy to adjust the axial position of the beam waist. In addition to being useful for system alignment and automated adjustments, some light sheet acquisition schemes translate the beam waist synchronously with the camera's rolling shutter to improve axial resolution (e.g. ASLM, Axially Swept Light Sheet Microscopy). The straightforward way to translate the beam waist is by adding a tunable lens at the entrance to the light sheet generator. ASI offers all the necessary hardware to implement ASLM, including both the tunable lens and light sheet generator.

Another application combines two tunable lenses to make an electronically-adjustable beam expander. A final use is to implement an electronically adjustable collimator for white light lasers, compensating for the fiber's wavelength-dependent divergence point.

The lens is made of an optic-quality deformable polymer manufactured by Optotune. By applying an electric current, the shape of the polymer changes. Thus, the focal length of the lens can be adjusted to a desired value within milliseconds. ASI-designed drive electronics have better performance than alternatives, and also allow tunable lenses to be easily synchronized with other microscope components.

Response time and tuning range depend on the exact tunable lens (and polymer) used; stiffer lenses are faster but have less tuning range. The standard Optotune tunable lens used by ASI has a 12 diopter tuning range and <15 ms transient response. Used with ASI's 4f relay, it produces 80 μm focus change with a 20x objective and 8 μm of focus change with a 60x objective. The tunable lens can be easily paired with an offset lens to adjust the center of the tuning range.

Modular Infinity Microscope

Tunable Lens

TGTLC Features

- Each card controls up to 2 tunable lenses
- Control with serial commands, manual input devices (knob or joystick), or a 0-5V analog signal
- Aliasing is reduced with an onboard 5th order filter
- For default lens: 15ms transient response, resonant frequency at 150Hz and 600Hz. Other lenses available.
- Includes compensation for temperature-induced focal shifts

Applications

- Acquire Z series by changing the focus position without moving the objective or sample
- Implement focus feedback, e.g. using ASI's XYZ Tracker Plugin in Micro-Manager
- Implement ASLM (axially swept light sheet) with ASI's cylindrical lens scanner
- Electronically-controlled beam expander
- Electronically-adjustable collimator

Part Numbers

- C60-TUNELENS-4F: 4F assembly including tunable lens and C-mount interfaces on both ends
- C60-TUNELENS-xxx: Optotune EL-10-30 lens in C60 system with compensating negative lens (various options)
- C60-TUNELENS-NC: Optotune EL-10-30 lens in C60 system, no compensating negative lens.
- C60-TUNELENS-K1: Kit to use the tunable lens with ASI's light sheet scanner
- TGTLC: TG-1000 control card for Optotune lens including temperature compensation.

Modular Infinity Microscope

Tubes and Tube Components



Tube Lenses

ASI Modular Infinity Microscope components consist of tube lenses along with adapters and accessories that either are primarily used in the collimated light space or adapters that are to be used on the image side. Collimated light adapters use the 38 mm diameter C60-RING system to connect components. Focus-side adapters attached to lens tubes with either a 30 mm diameter coupling to the I.D. of the C60-TUBE, or with a 50 mm coupling on the O.D. of the lens tube.

With infinity microscope systems, the objective can be spaced away from the tube lens without changing the optical magnification. This "infinity space" provides a region where other optical systems can be coupled to the microscope relatively easily. For epi-fluorescent illumination, a filter cube with a dichroic beam splitter can be added to provide the illumination path.

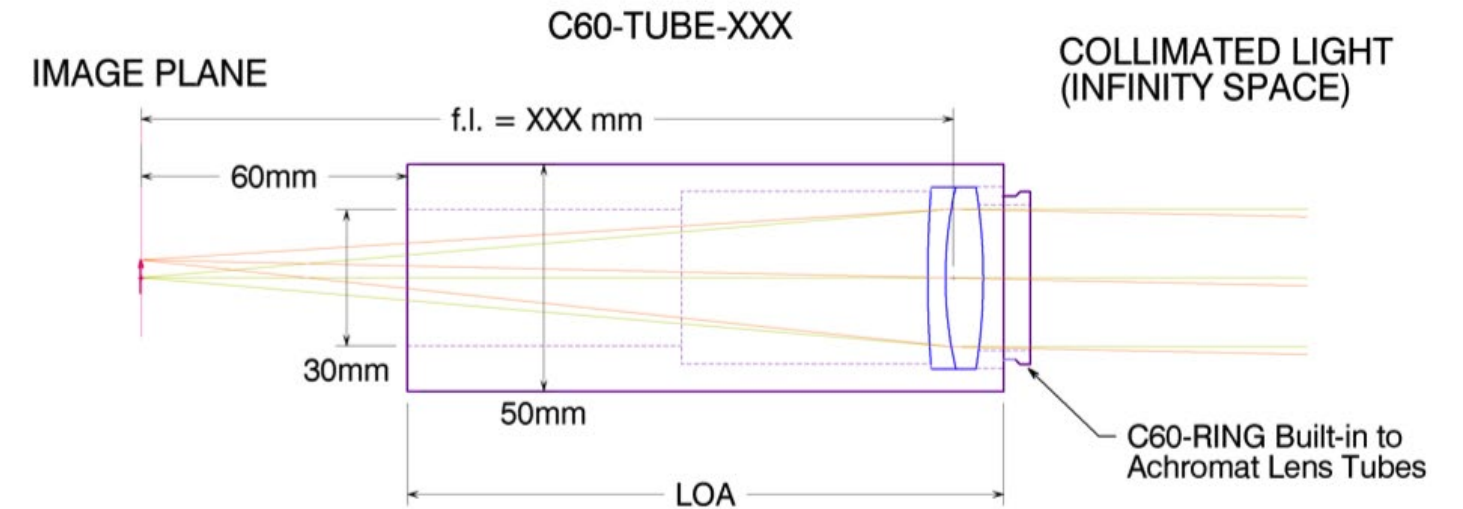

Modular Infinity Microscope

Tubes and Tube Components

Other Tube Lens Assemblies

In addition to the standard C60-TUBE-B, there are also several other options for tubes and tube lenses that can be used to obtain different final magnifications. The achromatic lens tubes, Tube-100, Tube-200, etc., includes the male ring end built into the assembly. A coupling C60-RING is required for Tube-B and Tube-Z13.

The distance from the end of the tube to the image plane is 60 mm for all tubes. The tubes have a 50 mm O.D. and are terminated with a 30 mm I.D. flange.

The table below lists the other options and specifications for the various tube lens assemblies.

Part Number	Lens F.L. (mm)	Magnification for Nikon Objectives	Magnification of Olympus Objectives	Lens Type	Length of Assembly (mm)
C60-TUBE-B	200	1.00	1.11	Nikon multi-element tube lens	126.2
C60-TUBE-Z13	164.5	NA	NA	Zeiss multi-element tube lens for 130mm objective-tube distance	121.1
C60-TUBE-100	100	0.50	0.56	Achromat	48.7
C60-TUBE-100D	100	0.50	0.56	Dual Achromat	64.6
C60-TUBE-160	160	0.80	0.89	Achromat	112.3
C60-TUBE-200	200	1.00	1.11	Achromat	152.7
C60-TUBE-300	300	1.50	1.67	Achromat	252.0
C60-TUBE-400	400	2.00	2.22	Achromat	352.0
C60-TUBE-125D	125	0.63	0.69	Achromat	94.1
C60-TUBE-140D	140	0.70	0.78	Achromat	105.3
C60-TUBE-70D	70	0.35	0.39	Achromat	16.0
C60-TUBE-180L	180	0.9	1.0	Nikon multi-element tube lens	113.2
C60-TUBE-180D	180	0.9	1.0	Dual Achromat	157.0



Modular Infinity Microscope

Tubes and Tube Components



Basic Tube Lens Module w/ Achromat Tube Lens C60-TUBE_XXX

Our basic tube lens modules come with an Achromat tube lens size of your choice. A male RING mount is part of tube so the C60-RING is not required.

Achromat tube lenses available:

- 100 mm (C60-TUBE-100)
- 160 mm (C60-TUBE-160)
- 200 mm (C60-TUBE-200)
- 250 mm (C60-TUBE-250)
- 300 mm (C60-TUBE-300)
- 400 mm (C60-TUBE-400)



Multi-Element Tube Lens Assembly C60-TUBE_XXXD

Our multi-element tube lens assembly comes with male RING mount so the C60-RING is not required. This assembly offers improved optical performance when compared to single achromatic lenses.

Sizes available:

- 100 mm (C60-TUBE_100D)
- 125 mm (C60-TUBE_125D)
- 140 mm (C60-TUBE-140D)
- 180 mm (C60-TUBE-180D)



Basic Tube Lens Module for Nikon Tube Lens C60-TUBE_B

Basic tube lens module with Nikon 200 mm tube lens. Excellent general purpose tube lens for Nikon or Olympus objectives.



Basic Tube Lens Module for Zeiss Tube Lens C60-TUBE_ZX

Basic tube lens module for use with 164.5 mm Zeiss tube lens. Your choice of infinity length.

Sizes available:

- 130 mm (C60-TUBE-Z13)

Modular Infinity Microscope

Tubes and Tube Components



Adjustable Focus Lens Tube

C60-FOCUS_TUBE-FL

Collimated space tube with provision to move a 25 mm diameter lens element with 25 mm travel. Used for TIRF systems to focus the laser to objective BFP. Specify F.L. of 25 mm Achromat lens. *This tube can come without a lens (C60-FOCUS_TUBE).*



Photo Part Kits

Includes a tube lens and c-mount adapter.

T 200 N-MMC: 200 mm Nikon Lens

T 125 D - MMC: 125 mm Dual Achromat Lens

T 100 D - MMC: 100 mm Dual Achromat Lens

T160 - MMC: 160 mm Achromat Lens

T 180 L - MMC: 180 mm Olympus Lens



C60-SPACER-ADJ

Adjustable spacer 0-30mm used with modified tube lenses to provide precise position of the lens element.



Extension Tubes

C60-EXT-XX

Our extension tubes come with male to female C60-RING mounts excluding the 15 mm tube, which is female to female.

Sizes available:

7.5 mm (C60-EXT-7.5)

15 mm (C60-EXT-15)

25 mm (C60-EXT-25)

37.5 mm (C60-EXT-37.5)

50 mm (C60-EXT-50)

75 mm (C60-EXT-75)



Adjustable Iris

Adjustable iris 1.5 mm minimum to 25 mm maximum diameter. In 19.8 mm extension tube with female ring fittings.

C60-IRIS

Modular Infinity Microscope

Cage Adapters and Components



Cage components provide flexible optical positioning when that is required. When building 4F systems, where a lens needs to focus at the back focal plane of an objective, a cage section can provide the required adjustment.

Cage rods are spaced on a 30 mm square and are 6 mm diameter. The ASI components are compatible with Thor Labs 30 mm cage parts.

Cage kits include the two C60-30CRM-30LM and a set of rods so that the cage assembly can be placed between standard C60 38 mm female ring mounts.

Add one or more of the parts above to hold desired optics.

C60-CAGE-80 - Kit of two (2) C60-30CRM-30LM and four (4) 80 mm cage rods, allows about 65 mm optical adjustment.

C60-CAGE-60 - Kit of two (2) C60-30CRM-30LM and four (4) 60 mm cage rods, allows about 45mm optical adjustment.



C60-30CRM-10LM

C60 38 mm ring to 30 mm cage rods adapter. It also has provision for 10 mm glue-in lens, and 56 mm O.D. x 9.4 mm I.D.



C60-30CRM-12.5LM

C60 38 mm ring to 30 mm cage rods adapter. It also has provision for 12.5 mm glue-in lens, and 56 mm O.D. x 9.4 mm I.D.



C60-30CRM-30LM

C60 38 mm ring to 30 mm cage rods adapter. It also has provision for 30 mm glue-in lens, and 56 mm O.D. x 29 mm I.D.



C60-30C-25LM

Mount for 25 mm diameter optics for 30 mm cage system, and 56 mm O.D. x 24.4 mm I.D.

Modular Infinity Microscope

Cage Adapters and Components



C60-30C-M11

M11 threads to 30 mm cage rods adapter replaces collimator with cage.



C60-30C-12.5 LM

C60 38 mm ring to 30 mm cage rods adapter with female ring mounts. It can be used without cage if needed it. Provision for 12.5 mm lens held by set screws (e.g. cylindrical lens).



C60-30C-M11-F

C60 38 mm ring to 30 mm cage rods adapter. It has provision for 10 mm or 12.5 mm glue-in lens, and 56 mm O.D. x 9.4 mm I.D. In addition, it comes with M11 female threads for collimator.

Modular Infinity Microscope

Focus Side Components



Silicon Photodiode with BNC Connector

Silicon photodiode with BNC connector. 100 mm area with a female C-Mount
C60-C-Mount-PD



C60 Fiber Launch

Assembly places for FC fiber optics connector tip at the image plane of a C60-TUBE_XXX lens. Fiber connector may be translated using a micrometer head adjuster. Used for TIRF system to set the TIRF angle. Motorized option available.
C60-FIBER-LAUNCH



C-Mount Fiber Adapter

Adapter has an FC/PC fiber connector on a female C-Mount thread that places fiber tip at image plane.
C-Mount-FIBER

Modular Infinity Microscope

Beamsplitter Cubes



CUBE I

Beamsplitter cube with fixed internal dovetail mount. Includes C60-DOVE-I. Internal cube not included.

C60-CUBE-I

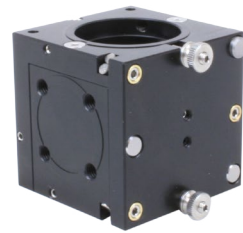

CUBE II

Beamsplitter cube with adjustable quick-change cube. Includes C60-DOVE-II. Internal cube not included.

C60-CUBE-II



CUBE III

Beamsplitter cube with externally adjustable internal cube. This cube is not quick-change but is more stable than CUBE-II. Includes C60-DOVE-III. Internal cube not included.

C60-CUBE-III



CUBE I Cube Holder

Beamsplitter cube holder section. Extras are required for faster cube swaps.

C60-DOVE-I



CUBE II Cube Holder

CUBE-II cube holder section with adjusting screws and magnets. Extras are required for faster cube swaps.

C60-DOVE-II



CUBE III Cube Holder

CUBE-III cube holder section with adjusting screws and spring-loaded shoulder bolts. Extras are required for faster cube swaps.

C60-DOVE-III

Modular Infinity Microscope

Beamsplitter Cubes



Cube Kits

Beamsplitter coupling kit. Contains the cube of your choice (I, II or III) and two (2) C60-RINGs.

MIM-CUBE-I-K

MIM-CUBE-II-K

MIM-CUBE-III-K



C60-MIRROR_Sliders

C60-MIRROR_SLDR_2mm – Slider to hold 36 mm x 25.5 mm x 2 mm mirrors for RA_2nd_PORT or SHORT_PORT cubes.

C60-MIRROR_SLDR_1mm – Slider to hold 36 mm v 25.5 mm x 1 mm mirrors for RA_2nd_PORT or SHORT_PORT cubes.



C60-3WMS-Mx

Three-Way manual port switch.

It includes C60-MIRROR_SLDR_xmm. Order mirror or dichroic separately.

MIM-CUBE-I-K

MIM-CUBE-II-K

MIM-CUBE-III-K



Short Port

Beamsplitter cube using C60_DICHROIC_SLIDER. Side port accepts 30 mm O.D. fitting. The C60-SHORT_PORT_L includes a 75 mm f.l. lens for focus using C60-3060_C-Mount. Short Ports can be used couple CRISP to microscope kits MIM 3, MIM 4 and to build Multi-color LED sight sources.

C60-SHORT_PORT

C60-SHORT_PORT_L

Modular Infinity Microscope

Cube Components



Filter Cube

Filter cube for C60 Cubes (U-MF2 replacement). Holds up to 2 mm dichroic glass.

C60-D_CUBE



Large Format Filter Cube

Large format (32 mm x 44 mm) dichroic mirror holder for C60-CUBE. No provision for EM or EM filters.

C60-FCUBE_32x44

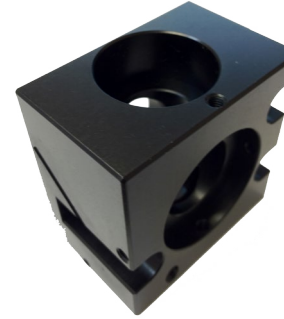

Second Level Port Assembly

Right angle 2nd level port assembly for use with LS-50. It includes dichroic slider and coupling tube. Part of MIM 2 System Kits.

C60-RA_2nd_PORT



Cube Sliders

C60-CUBE_SLD – Automated four (4) position filter cube slider. It provides automated switching of dichroic, emitter and exciter filters. It can be used stand-alone or mounted to LS-50 focus assembly with C60-RA_OBJ_FC_MNT; typical switch time between adjacent filters is < 250 ms.

C60-CUBE_SLD-MN – Manual four (4) position filter cube slider. Provides manual switching of dichroic, emitter and exciter filters. Can be used stand-alone or mounted to LS-50 focus assembly with C60-RA_OBJ_FC_MNT.



Cube Holder

Female dovetail mount for 25 mm or 30 mm right angle mirrors or cube beamsplitters. For use with C60-CUBE.

C60-25mm_CUBE-HOLDER

C60-30mm_CUBE-HOLDER



Right Angle Mirror

25 mm or 30 mm right angle mirror on dovetail holder.

C60-25mm_CUBE-RA-MIRROR

C60-30mm_CUBE-RA-MIRROR

Modular Infinity Microscope

Camera Mounts



C-Mount Adapter

Male C-Mount camera adapters for C60-TUBE. Their dimensions are 24 mm I.D., 50 mm O.D., and 40 mm O.D. for the C60-9060-C-Mount respectively and 60 mm from focus in both cases.

C60-5060-C-Mount
C60-9060-C-Mount



Male C-Mount Camera Adapter

Male C-Mount camera adapter for C60-TUBE with slot for a filter slider. Show with a slider e.g. C60_2+1 and refer to the slider options.

C60-SLDR-C-Mount

Modular Infinity Microscope

Camera Mounts



Direct Bayonette Mount

Camera mount for Hamamatsu D2 camera.

C60-Eng-MOUNT



T-Mount Adapter

T-mount adapter for C60-TUBE_B. 30 mm I.D. 60 mm from focus.

C60-T_MOUNT

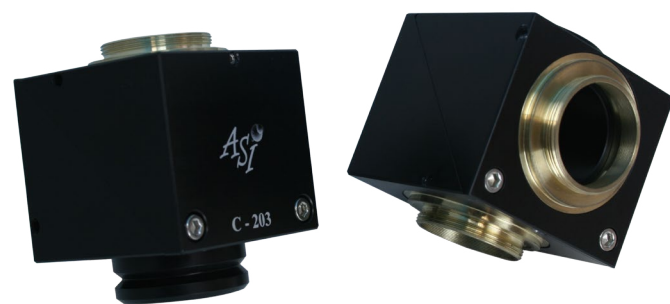

Dual C-Mount Splitter

Dual C-Mount Splitter (DCMS) provides two (2) parfocal C-Mount ports when mounted on many common microscopes.

DCMS



Female C-Mount

For use with C60 tube lens to produce a collimated beam from the microscope camera port.

C60-Female_C-Mount



Large Format C-Mount Adapter

Large format C-Mount adapter for C60-TUBE_B. 30 mm I.D. 60 mm from focus. It includes C60-T_MOUNT.

C60-LF_C-Mount



Rotatable Camera C-Mount Adapter

Rotatable camera C-Mount adapter. May be manual or motorized adjust. Allows precise rotational alignment of the camera. The motorized version requires a controller servo channel and has a rotational encoder resolution of < 0.01 degree with max rotational speed 8 degrees/sec.

C60-3060_CM
C60-3060_CM_MO

Modular Infinity Microscope

Illumination Components



Excitation Condenser Kit

MIM-EXCITE-COND100-K – Contains C60-ILLUM-ADPT and C60-TUBE-100.

MIM-EXCITE-COND160-K – Contains C60-ILLUM-ADPT and C60-TUBE-160.



Liquid Light Guide Coupling

Liquid light guide illuminator coupling for 5 mm o.d. 3 mm liquid light guide.

MIM-LLG_ILLUM



Lamp Adapter

Kohler coupler between LLG_ADPT and C60-TUBE-XXX; no iris. It uses LLG_ADPT iris as field stop.

C60-LAMP_ADPT_3



MIM-LED-LAMP-NR wavelength Options

Peak Wavelength in nm	Approx. Power in mW ¹	Spectral FWHM in nm
365	TBD ²	20
385	TBD ²	20
405	TBD ²	30
455	330	20
490	50 ³	20
505	TBD ²	20
525	200	50
560	136	100
590	82	80
640	200	25
660	TBD ²	30
740	145	30
850	236	30
940	330	40
Cool White	272	na

For more information go to asiimaging.com/docs

LED Lamp

MIM-LED_LAMP – High brightness LED LAMP illumination. You specify LED color. This LAMP comes with a 25 mm iris.

MIM-LED_LAMP-NI – High brightness LED LAMP illumination. You specify LED color. This LAMP does not come with an iris.

MIM-LED_LAMP-NE – High brightness LED LAMP illumination. You specify LED color. This LAMP does not come with an iris or regulator.

MIM-LED_LAMP-NR – High brightness LED LAMP illumination. You specify LED color. Used with TG Card. This LAMP comes with and Iris but does not come with a regulator.

Modular Infinity Microscope

Illumination Components



Transillumination Kit with DIC Option

Requires the Olympus Transillumination Kit. The DIC-OPTION Kit has: IX-LWPO, U-DICTS, IX2-DIC20 and IX2-DIC40.

OLY-DIC-OPTION



Six Position Automated Objective Changer

Olympus threads. Olympus U-D6REM-1-6 six position motorized nose piece. This Olympus part is modified with an encoder motor from ASI for positioning. A manual changer is also available. We can also provide a manual Nikon changer.

U-R156M6

U-R156 (Manual)



Objective Adapters

C60-OBJ-M25 - Objective adapter for Nikon M25-0.75 threads (NIKON CFI 60 series objectives).

C60-OBJ-RMS - Objective adapter for RMS threaded objectives (Olympus).

C60-OBJ-M26 - Objective adapter for M26 x 32 TPI threads (Mitutoyo).

C60-OBJ-M27 - Objective adapter for M27 x 1.0 (Zeiss).

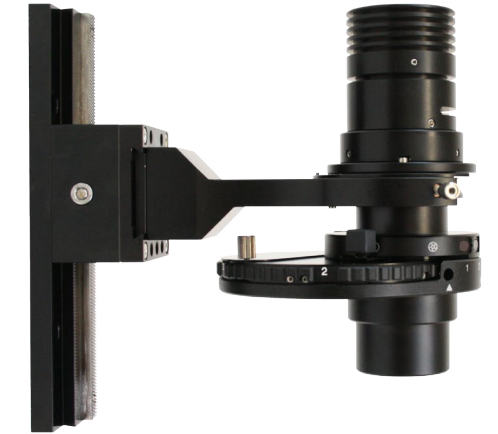

Transillumination Kit

Transillumination kit based upon Olympus IX2-LWUCD condenser. Includes: OLY-IX2-LWUCD, C60-OLY-COND-MNT, C60-OLYC2LMP, Z-Rack and MIM-LED-LAMP.

OLY-TRANS-ILLUM

Modular Infinity Microscope

Objective Threads and Objective Focusing Components



Objective Holders

We have many different types of objective holders, please contact us to find the one that will best suit your system needs.

- C60_RA_OBJ_MNT**
- C60_RA_ADJ_OBJ_MNT**
- C60_RA_ADJ_OBJ_FC_MNT**
- C60-RA-OBJ-DOVE**
- C60-RA-RING-MNT**



Objective Mount

Objective mount direct on ring mount.

*Shown with objective adapter.

- C60-OBJ_MNT**

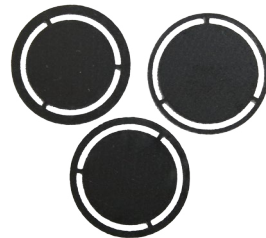

Slider Dark Field Set

Slider set.



Slider Options

- C60-POL-SLDR** – Slider option for the MIM-XMIT-COND or C60-SLDR_C_MOUNT with rotatable polarizer on end position. It includes polarizer with clear aperture of 19 mm.
- C60-SLIDE_2+1** – Three (3) position slider for 25 mm filters with IRIS on one end for C60 manual slider components.
- C60-SLIDE_4** – Four (4) position slide. It holds four 25 mm diameter filters up to 5.5 mm thick.



Universal Coupling Ring

Universal coupling ring for attachments to C60-CUBE. 30 mm clear aperture.

- C60-RING**



C60-SLDR-TUBE

20 mm long extension tube with slot for filter slide.

Modular Infinity Microscope

Coupling Rings and Ring Adapters



Universal Coupling Ring

C60-RING_25F (RING_D) – Universal coupling ring for attachments to C60-CUBE with provision for 25 mm filter (set-screw).

C60-RING_32F – Universal coupling ring for attachments to C60-CUBE with provision for 32 mm filter (glue-in).



Blank Port Cover

Port covers. Has M11 threads for fiber collimators.

- C60-COVER**



C60 Ring to Filter Wheel Adapter

MIM to FW-1000 adapter. This is a useful female RING adapter for custom applications.

- C60-FW**



Aperture Stop

Aperture stop in 15, 20 or 25 mm diameters. These are installed in the C60-RING.

- C60-STOP_15**
- C60-STOP_20**
- C60-STOP_25**



Adjustable Coupling Ring

Universal coupling ring with +/- 2 mm adjustments possible. 25 mm clear aperture.

- C60-RING-ADJ**



C60 Ring to Filter Wheel Adapter Set

FW-1000 collimated space mounting kit. It contains two (2) C60-FW adapters and one C60-RING.

- C60-FW-SET**

Versatile Test Stand

VTS-2300 Test Stand

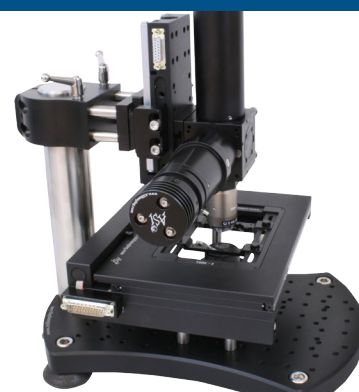

Features

- Base is a Breadboard on 25 mm centers tapped for M6 screws with threaded holes for risers for TE/TI-2000, TE-300, IX-71/81, DMI, and MS-2000 stages
- Base feet provide vibration isolation
- Z riser is adjustable on pillar blocks
- Z motion from LS-50, LS-100, or LS-150 linear stage
- Z illumination can use LED, LED and a Condenser (from below), or fiber illumination (from above)
- Observation is with a Modular Infinity Microscope

LS-Series Linear Stage

LS-Series linear stages provide sub-micron accuracy, deriving their precise control by using closed-loop DC servomotors and employing high resolution rotary encoders for positioning feedback. An optional linear encoder can be added to the unit to provide even greater positioning accuracy.

The units have built-in limit switches, and can be configured with a number of lead screw options as outlined in the table below.

Lead Screw Pitch Options	Rotary Encoder Resolution	Maximum Speed
25.40 mm (Ultra-coarse)	88 nm	28 mm/sec
12.70 mm (Super-coarse)	44 nm	14 mm/sec
6.35 mm (Standard)	22 nm	7 mm/sec
1.59 mm (Fine)	5.5 nm	1.75 mm/sec
0.635 mm (Extra-Fine)	2.2 nm	0.7 mm /sec

Basic Components

Infinity Space Beam Splitter Cube – can be used for Epi-fluorescence filter cube or as right-angle objective adapter.
 Objective Adapter – options for Nikon CFI60, Mitutoyo, or Olympus RMS thread objectives.
 Universal Coupling – used on all infinity-space components for design flexibility.
 C-Mount Beam Splitter - provides a second camera/detector port
 Filter Wheel Adapter - Use with ASI FW-1000 Filter Wheel

Tube Lens	200 mm f.l.
Beam Splitter	Olympus AX/BX/IX series cube
Beam Splitter Optical Length	60 mm
Objectives Supported	Nikon CF160 Series, Mitutoyo LWD Series, *Olympus ∞ corrected
Camera Port	C-Mount

**Olympus objectives will have overall magnification 1.11 x objective marking*

Versatile Test Stand

VTS-2300 Test Stand Components

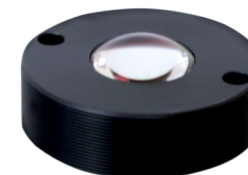

VTS Condenser

Condenses regular light into collimated light and allows adjustment of the collimated beam.

VTS-COND



Lower Condenser Carrier

Adjustable condenser carrier for Versatile Test Stand (VTS). Allows for focus and centering of the condenser. VTS-COND-ASSM Includes Olympus Abbe Condensor and adjustable focusing rack.

VTS-COND

VTS-COND-ASSM



VTS Rack and Pinion

Z-Rack and pinion positioner for manually focusing condenser. The pinion provides very precise positioning capabilities.

Z-Rack



Manual DOVE Adjustment

Z-Rack and pinion positioner for manually focusing condenser.

VTS-2107



Post Mount

Diameter of 2" vertical stand system support arm, 10" L for custom upright configuration.

VTS-2125

Microscope Support System

Microscope Support Kits and Components



Microscope Support System

Allows direct support of cameras or other items from bread-board table. An example use case is to support diSPIM cameras from the table to avoid coupling camera fan vibration to the microscope body.

Feet accommodate with either metric or imperial bread board hole spacing. 1.5" stainless steel rods and steel adapters are used to hold heavy loads without flexing. Height and depth of clamp is easily adjusted by user. Steel rods can be cut to desired length.

K1 - supports the camera with the attached tube lens. Clamp has 50 mm ID.

K2 - supports the camera with an attached FW1000 filterwheel. Special piece connects support with filterwheel body.

K3 - stainless steel adapter from camera support kit to dovetail.

K4 - stainless steel support arm with 45 degree face for dovetail connection.



Post Mount Base

Support base for post mount, bolts to imperial or metric breadboard.

PM-BASE



Post Mount Collar

Safety collar for 1.5" dia. Raisers.

VSBC-1.5

Microscope Support System

Microscope Support Kits and Components



Post Mount Clamp Arm

coated steel S-shaped support arm including split ring clamp. Unique part for the K-1

PM-CLAM-ARM

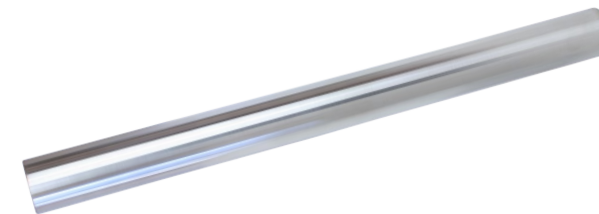

17", 14", and 13" Post

1.5" dia. Stainless steel (SS) riser, 17.25", 14.25" and 12.98", long 3X M8x1.25 on Ø.984 D.B.C. (diSPIM or RAMM no incubator)

PM-BAR-17

PM-BAR-14

PM-BAR-13



Post Mount Dovetail Angle Adapter

Stainless steel support arm with 45 degree face for dovetail connection. Unique part for the K-4

PM-DV-ANGLE



Post Mount Filterwheel Support Arm

Filterwheel support arm. Unique part for the K-2

PM-FW-ARM



10", 7" and 5" Post

1.5" dia. Stainless steel (SS) horizontal, 7" long 3X M6x1.0 on Ø.984 D.B.C.

PM-BAR-10

PM-BAR-7

PM-BAR-5



Post Mount Dovetail Adapter

Stainless adapter from camera support kit to dovetail. Unique part for the K-3

PM-DV-ADPT

Controllers

TG-1000 Tiger Controller



The Tiger controller is an expandable modular card rack based system. Racks are available with either 8 or 16 card slots. The Tiger is designed to control one or more microscope workstations simultaneously from a single USB connection.

TG-1000 Configurations:

- **TG8-BASIC** - Includes TG8, TGCOM, 2) TGDCM2, SA-JOY+ZF Controls four DC servo motors, Com card w/USB, Power supply, and Joystick w/ two knobs; 5 more free slots.
- **TG16-BASIC** - Includes TG16, TGCOM, 2) TGDCM2, SA-JOY+ZF Controls four DC servo motors, Com card w/USB, Power supply, and Joystick w/ two knobs; 13 more free slots.
- **TG8** - Eight-slot power supply and chassis / box for motion control cards. Bench size 9.25"W x 5.5"H x 10.25"D 100-240 VAC Input.
- **TG16** - Sixteen-slot Power supply and chassis / box for motion control cards. Rack-mount size 19"W x 5.5:H x 12.5"D 100-240 VAC Input.

TIGER Cards Currently Available:

- **TGCOM** - Communication card. It connects to host computer with USB interface, and provides communication with all cards in the TG8 or TG16 box.
- **TGDCM2** - Dual axis motion control card - one slot.
- **TGADEPT** - Single axis motion control card - two slots.
- **TGDAC** - DAC voltage control card, used for controlling 0-10V piezo devices.
- **TGFW** - Dual FW-1000 Filter wheel control card - two slots.
- **TGMM4** - Four-axis micro-mirror scanner control card.
- **TGDAC** - Piezo DAC Card. It provides 2 DAC (0 to 10 V) outputs to control third party piezos.
- **TGCRISP** - CRISP card. It provides CRISP focus control of DC servo stage such as LS-50, has TTL I/O.
- **TGPLC** - Field-programmable card for digital logic, like a mini-FPGA. Has eight front-panel I/O ports plus connections to the Tiger backplane.
- **TGTTL** - Jumper-configurable TTL card with four I/O ports. For most applications this has been replaced by TGPLC.
- **TGBUF** - Two-channel 50ohm TTL driver.
- **TGLED** - Tiger plug-in card that can drive up to four MIM LED-LAMP-NRs (high brightness LED illuminators).

Product Numbers:

TG8: Eight-slot power supply and chassis/box for motion control cards. Bench size 9.25"W x 5.5"H x 10.25"D. 100-240 VAC Input.

TG16: Sixteen-slot power supply and chassis/box for motion control cards. Rack-mount size 19"W x 5.5"H x 12.5"D. 100-240 VAC input.

Controllers

MS-2000-WK Multi-Axis Stage Controller



Features

- 100 MHz Microcontroller for faster command processing and servo control
- Closed-loop DC servo control of up to four motorized axes
- Firmware upgradable via serial connection
- 0-10V DAC for single piezo axis control
- Remembers last position on power down/up
- LCD display shows axes coordinates and status
- "Zero" and "Home" buttons for simple stand-alone operations
- USB or RS232 serial control with baud rates to 115200 Baud
- Compact ergonomic tabletop control unit 6" D x 9" W x 3" H (16½ x 23 x 9 cm)

Options Supported

- Linear encoders
- Piezo Z-axis control
- Hardware video autofocus
- Z-axis drives with electromechanical clutch
- Raster and serpentine scanning routines with TTL synchronization
- Leica Smart Move™ Digital Potentiometers for XY motion control
- TTL control of moves to previously stored locations
- Bare boards and custom firmware are available for OEM applications

Part Numbers

- MS2: Two Axis Controller**
- MS3: Three Axis Controller**
- MS4: Four Axis Controller**
- MS5: Five Axis Controller**

Specifications

Digital Servo Loop Time	250 μs × number of axes
Digital-Closed-Loop Speed Dynamic Range	> 40 dB
Motor Type	Brushed DC Servo Motors
Maximum Motor Current	1.5 Amp
Motor Voltage	6-24 V
Encoder Options	Internal Rotary or External Linear Encoders are supported
Number of Axes	Up to four Motor Axes, plus DAC Channel for Piezo Drive
Manual Controls	XY Joystick, Control Wheel
Display	4-line by 40-character LCD Display shows Axis Positions and Status
Computer Interface	RS232 Serial and USB
Interface Baud Rate	9600, 19200, 115200
Electrical Requirements from External Power Supply	24V DC 1.5 Amp

Controllers

RM-2000 Rack Mount Stage Controller



Features

- 2U 19" Rack Mount Control Unit: 22.8 cm D x 48.3 cm W x 8.1 cm H (9" x 19" x 3.2")
- 100 MHz Microcontroller for faster command processing and servo control
- Closed-Loop DC servo control of up to four motorized axes
- 0-10 Vdc DAC output for additional analog control
- Firmware upgradable via serial connection
- Remembers last position on power up
- LCD display shows axes coordinates and status
- USB or RS-232 serial control with rates to 115200 baud
- "Zero", "@", and "Home" buttons on joystick
- Left- or Right-Hand joystick unit

Options Supported

- Z-drives, with clutch switch
- Dual filter wheel control
- Dual shutter control
- Piezo Z-axis control
- Linear encoders (XYZ)
- Hardware video autofocus
- Raster and serpentine scanning routines with TTL synchronization
- Leica Smart Move™ Digital Potentiometers for XY motion control
- TTL control of Moves to previously stored locations
- Multi-output hardware sequencer functions
- Bare boards and custom firmware are available for OEM applications

Specifications

Digital Servo Loop Time	1 millisecond per Axis
Digital-Closed-Loop Speed Dynamic Range	> 40 dB
Motor Type	Brushed DC Servo Motors
Maximum Motor Current	1.5 Amp
Motor Voltage	6 – 24 Vdc
Encoder Options	Internal Rotary or External Linear Encoders Supported
Number of Axes	Up to four Motor Axes, plus DAC Output Channel
Manual Controls	XY Joystick, Control Wheel, Zero, @, and Home Buttons, Filterwheel Advance to Next, Shutter Toggle, Controller Reset
Display	4-line by 40-character LCD Display shows Axes Positions and Status
Computer Interface	RS-232 Serial and USB
Interface Baud Rate	9600, 19200, 115200
Filter Wheel Switching Time	< 40 ms
Shutter Switching Time	≤ 8 ms
Power Requirements	Voltage 100 – 240 Vac 50/60 Hz Current 2.3 Amp (max)

Controllers

RM-2000 Rack Mount Stage Controller



RM-2000 Part Numbers

RM-2: 19 inches rack mounted two axis stage controller for use with closed loop D.C. servo motor stages. Control electronics included ASI's proven antibacklash algorithm to increase bidirectional accuracy.
RM2-FW: Includes Filter wheel
RM-3: Same as above, but 3 axis unit
RM3-FW: Includes Filter wheel
RM-4: Same as above, but 4 axis unit
RM4-FW: Includes Filter wheel

Joystick Part Numbers

The RM-2000 Rack Mount Stage Controller requires the Stand Alone Joystick. The part numbers for the joystick are:
SA-JOY: For XY System
SA-JOY-Z: For XYZ System
SA-JOY-ZF: For XYZ and second Z System



The MFC-2000 has been specifically designed to provide a high resolution and highly repeatable, means of controlling the focus/Z position of the microscope stage. Precise control of the microscope's focus is obtained through the use of a closed-loop DC servomotor employing high resolution encoders for positioning feedback. By using closed-loop control of the focus position, there is no chance that the focus point can be lost as can occur with open-loop stepper motors.

Rather than a one-size-fits-all design, the Z-axis drive is custom designed for each microscope, and when installed, they become an integral part of the microscope. A switch located on the control console operates a clutch that disengages the motor drive from the fine focus shaft when the drive is not needed. When disengaged, the position still displays and is still available for interrogation by computer, and the microscope can be focused manually without any drag or twisting cables.

Installation of the Z-axis drive requires no modification to the microscope other than removal of the fine focus knob and replacement of a back plate or base plate, depending on the particular microscope. All of the necessary hardware components, tools and detailed instructions, including a videotape on installing the drive, are provided with every unit.

The microprocessor-controlled MFC-2000 control unit provides for RS-232 communication with a host computer. High-speed serial communication using USB is also possible.

Part Number

**MS1: Single Axis Controller
Z-Axis Drive**

ASI Video Autofocus

Auto Focus option is available for stages with ASI Z-axis drives and requires a composite video signal (either NTSC or PAL).

Features

- Closed- loop DC servo control of z-axes for precise positioning and highly repeatable focusing
- Compact ergonomic tabletop control unit size is 6" D x 9" W x 3" H
- Backlit LCD display shows Z coordinates
- Utilizes ASI's proven Z-axis drives
- Microprocessor control with RS232-C serial communications
- Z-axis clutch for easy switching between manual and motor-driven focus control
- "Zero" and "Home" button for simple stand-alone operations
- USB serial computer interface

Specifications for Standard Configuration

Z axis resolution (encoder step)	0.05 μ m
Z axis repeatability	\pm 0.1 μ m
Z axis maximum velocity	0.6mm/sec

Contact ASI for assistance to discuss your microscope information.



Linear Encoder Options for Z-Axis

Type	Model	Resolution	Stroke
Heidenhain	MT 1271	50 nm	12 mm
Heidenhain	MT 2571	50 nm	25 mm

Product Compatibility

- Leica – Aristoplan, Diaplan, DM1000, DM2000, DM2500, DM4000, DM4500, DM5000, DM6000, DMIRB, DMIRBE, DMIRE, DMIRE2, DMLB, DMLS, DMLFS, DMRB, DMRP, DMRXP, Laborlux-D, Laborlux-S, Microplan, Orthoplan
- Nikon – AZ100, Diaphot TMD, Diaphot 200, Diaphot 300, Diaphot Eclipse TE200, Diaphot Eclipse TE300, Diaphot Eclipse TE2000, Eclipse 80i, Eclipse 90i, Eclipse 400, Eclipse 600, Eclipse 600FN, Eclipse 800, Eclipse 1000, Eclipse Ti, Labophot, Microphot FXA, Microphot SA, Optiphot, Optiphot 1, Optiphot 2, Optiphot 200, Optiphot UD, SMZ800, SMZ1000, SMZ1500
- Olympus – AX70, BH2, BX41, BX50, BX50WI, BX51, BX51WI, BX60, BX61, BX61WI, IX50, IX51, IX70, IX71, MVX Stereo, MX50, SZX12 Stereo, SZX16 Stereo
- Zeiss – Axiomager, Axiolab, Axioplan, Axioplan II, Axiophot I, Axiophot II, Axioskop, Axioskop II, Axioskop FS, Axioskop FS II, Axiovert 35, Axiovert 100, Axiovert 100M, Axiovert 135M, Axiovert 200, Axio Observer, IMC 35, Standard 16, Universal

Piezo Stages

PZ-2000 Series Automated Stage with Piezo Z-Axis Top Plate



The PZ-2000 XYZ stage has been specifically designed to provide a high resolution, and highly repeatable, means of controlling the X, Y, and Z position of the microscope stage. The XY axes derive their precise control through the use of closed-loop DC servomotors employing high-resolution rotary encoders for positioning feedback. By using closed-loop control for the stage position, there is no chance that the stage will become lost, as can occur with open-loop micro-stepped stages after a number of moves and direction changes. The XY stage utilizes crossed-roller slides, high-precision lead screws, and zero-backlash miniature geared DC servomotors for smooth and accurate motion. The top plate of the stage accepts standard K-size slide inserts that are available for any sample, i.e., slides, petri dishes, multi-well plates, etc. The slide insert is moved in the Z-axis via a piezo element with a range of 150 μm with nanometer accuracy (300 μm and 00 μm range is also available). By moving the sample in the Z-plane, any objective can be used, eliminating twisting wires or needed spacers as required when a piezo element is put onto a single objective. The microprocessor-controlled MS-2000 control unit provides for RS-232 and USB communication with a host computer for control of the XYZ axes. The stage, controllers, and top plate are sold separately.

Features

- Closed-loop control of the X, Y, and Z-axes for precise positioning and highly repeatable focusing
- Wide dynamic speed range with adjustable trapezoidal move profiles
- Smooth adjustable dual-range joystick control
- Backlit LCD display shows X, Y, and Z coordinates
- "Zero" and "Home" button for simple stand-alone operations
- Compact ergonomic tabletop control unit size is 6" D x 9" W x 3" H (9 cm x 23 cm x 16½ cm). Rack mount controller with stand-alone joystick is also available.
- Proven operation with many popular software packages
- Travel range will scan full well plate in most circumstances

PZ-2000FT Options

- XY axes Linear Encoders for high-accuracy positioning. Linear encoder resolution is 10 nm, with a scale accuracy of 0.3 μm per 10mm and 3 μm per 100mm. Positioning resolution at sample is < 50 nm
- Auto Focus (requires NTSC or PAL composite video signal)
- ASI's proven line of Z-axis drives can also be added to the fine focus shaft of the microscope to provide Z-axis positioning with a resolution of 50 nm throughout the range of the microscope's travel. The piezo unit can then be used for fast and accurate Z-axis positioning to any point within the range of travel
- Other lead screw pitches are available for faster XY translation, or for more precise positioning when using standard rotary encoders
- Stage Wings for even more room for attachments

Specifications for Standard Configuration

XY axis range of travel	120 mm x 110 mm
XY axis resolution (encoder step)	0.088 μm
XY axis lead screw accuracy	0.25 $\mu\text{m}/\text{mm}$
XY axis RMS repeatability	< 0.7 μm
XY axis maximum velocity	7 mm/sec

Piezo Stages

PZ-2000 Series Automated Stage with Piezo Z-Axis Top Plate

ADEPT Piezo Controller Specifications

Specification	PZ-2150FT	PZ-2300FT	PZ-2500FT
Piezo Travel Range (+/- 5%)	150 μm	300 μm	500 μm
Piezo smallest move / resolution*	2.2 nm	4.5 nm	7.6 nm
Maximum Load for full range travel	2Kg	1Kg	1Kg
Transient Response time**	11 – 15 ms		
External Analog input (BNC)	0 to 10 Volts		
Maximum Input Frequency	20 Hz		
Maximum Continuous Output Current	13mA		

**Time taken to travel 10%-90% for moves below 30% travel range with 600 grams load.

*In external input mode, use of a higher bit DAC will increase resolution. For example a 0-10 analog voltage from the DAC results in the following:

PZ-2150FT		
External Analog input	Steps	Resolution
16 Bit DAC	65536	2.2 nm
17 Bit DAC	131075	1.1 nm
18 Bit DAC	262144	0.55 nm

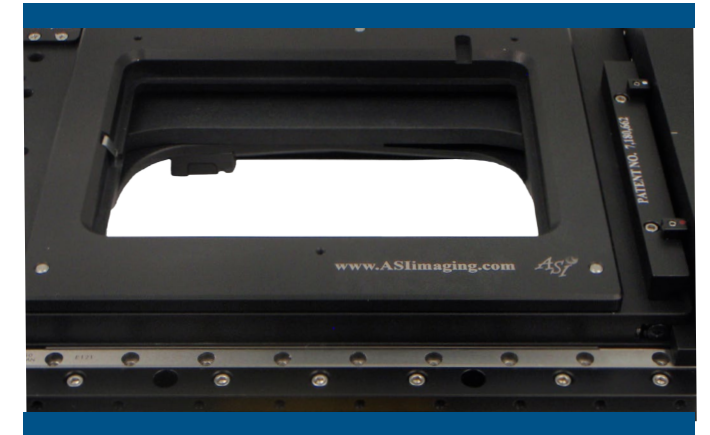

Part Numbers

Piezo Z top plate option. Top plate of stage with piezo Z positioning with sub-nanometer accuracy.

PZ-2150: Provides 150 μm of Z travel.

PZ-2300: Provides 300 μm of Z travel.

PZ-2500: Provides 500 μm of Z travel.

Product Compatibility

- Leica
- Nikon
- Zeiss

Piezo Stages

PZ-2000FT Series Automated Stage with Piezo Z-Axis Top Plate



The PZ-2000FT XYZ stage has been specifically designed to provide a high resolution, and highly repeatable, means of controlling the X, Y, and Z position of the microscope stage. The XY axes derive their precise control through the use of closed-loop DC servomotors employing high resolution rotary encoders for positioning feedback. By using closed-loop control for stage position, there is not chance that the stage will become lost, as can occur with open-loop microstepped stages after a number of moves and direction changes. The XY stage utilizes crossed-roller slides, high precision lead screws, and zero backlash miniature geared DC servomotors for smooth and accurate motion. The top plate of the stage accepts standard K-size slide inserts that are available for any sample, i.e., slides Petri dishes, multi-well plates, etc. The slide insert is moved in the Z-axis via a piezo element with a range of 150 μm with nanometer accuracy (300 μm and 500 μm range is also available). By moving the sample in the Z-Plane, any objective can be used, eliminating twisting wires or needed spacers as required when a piezo element is put onto a single objective. The microprocessor-controlled MS-2000 control unit provides for RS-232 and USB communication with a host computer for control of the XYZ axes.

Features

- Flat stage top allows easy placement of micromanipulators on either side
- Closed-loop control of the X, Y, and Z-axes for precise positioning and highly repeatable focusing
- Wide dynamic speed range with adjustable trapezoidal move profiles
- Smooth Adjustable dual-range joystick control
- Backlit LCD display shows X, Y, and Z coordinates
- “Zero” and “Home” buttons for simple stand-alone operations
- Compact ergonomic tabletop control unit size is 6” D x 9” W x 3” H (9 cm x 23 cm x 16.5 cm). Rack mount controller with stand-alone joystick is also available
- Travel Range will scan full well plate in most circumstances
- Proven operation with many software packages

PZ-2000FT Options

- XY axes Linear Encoders for high-accuracy positioning. Linear encoder resolution is 10 nm, with a scale accuracy of 0.3 μm per 10mm and 3 μm per 100 mm. Positioning resolution at sample is < 50 nm.
- Auto focus (requires NTSC or PAL composite video signal).
- ASI’s proven line of Z-axis drives can also be added to the fine focus shaft of the microscope to provide Z-axis positioning with a resolution of 50 nm throughout the range of the microscope’s travel. The piezo unit can then be used for fast and accurate Z-axis positioning to any point within the range of travel.
- Other lead screw pitches are available for faster XY translation, or for more precise positioning when using standard rotary encoders.

Piezo Stages

PZ-2000FT Series Automated Stage with Piezo Z-Axis Top Plate

ADEPT Piezo Controller Specifications

Specification	PZ-2150FT	PZ-2300FT	PZ-2500FT
Piezo Travel Range (+/- 5%)	150 μm	300 μm	500 μm
Piezo smallest move / resolution*	2.2 nm	4.5 nm	7.6 nm
Maximum Load for full range travel	2Kg	1Kg	1Kg
Transient Response time**	11 – 15 ms		
External Analog input (BNC)	0 to 10 Volts		
Maximum Input Frequency	20 Hz		
Maximum Continuous Output Current	13mA		

**Time taken to travel 10%-90% for moves below 30% travel range with 600 grams load.

Specifications for Standard Configuration

XY axis range of travel	120 mm x 110 mm
XY axis resolution (encoder step)	0.088 μm
XY axis lead screw accuracy	0.25 $\mu\text{m}/\text{mm}$
XY axis RMS repeatability	< 0.7 μm
XY axis maximum velocity	7 mm/sec

*In external input mode, use of a higher bit DAC will increase resolution. For example a 0-10 analog voltage from the DAC results in the following:

PZ-2150FT	Steps	Resolution
External Analog input		
16 Bit DAC	65536	2.2 nm
17 Bit DAC	131075	1.1 nm
18 Bit DAC	262144	0.55 nm



Product Compatibility

- Leica – DMI3000, DMI4000, DMI5000, DMI6000, DMIRB, DMIRBE, DMIRE, DMIRE2
- Nikon – Diaphot Eclipse TE2000, Eclipse Ti
- Olympus – BX50WI, BX51WI, BX61WI, IX70, IX71, IX81
- Zeiss – Axiovert 200, Axio Observer

Piezo Stages

IPZ-3000 Series Piezo Z-Axis Top Plate Insert and Sample Holders



The IPZ-3000 series piezo inserts will fit in most microscope stages with the standard 110 mm x 160 mm (K-size) stage insert opening. The piezo insert uses the same proven technology as our PZ-2000 series as a simple retrofit control on an existing XY stage. Several sample holders are available to fit the IPZ-3000 inserts for holding small dishes, slides or chambers. The piezo can be controlled with the MS-2000 controller, providing both USB and RS-232 communication to a host computer. Users with MS-2000 configuration for XY only can upgrade their controllers for Z control.

Features

- Proven operation with many software packages
- Closed loop control of the Z-axis position for highly repeatable focusing
- Several travel ranges available: 150 um, 300 um, and 500 um.

Product Compatibility

- Leica – DMI3000, DMI4000, DMI5000, DMI6000, DMIRB, DMIRBE, DMIRE, DMIRE2
- Nikon – Diaphot Eclipse TE2000, Eclipse Ti
- Olympus – BX50WI, BX51WI, BX61WI, IX70, IX71, IX81
- Zeiss – Axiovert 200, Axio Observer

ADEPT Piezo Controller Specifications

Specification	PZ-3150FT	PZ-3300FT	PZ-3500FT
Piezo Travel Range (+/- 5%)	150 um	300 um	500 um
Piezo smallest move / resolution*	2.2 nm	4.5 nm	7.6 nm
Maximum Load for full range travel	2Kg	1Kg	1Kg
Transient Response time**	11 – 15 ms		
External Analog input (BNC)	0 to 10 Volts		
Maximum Input Frequency	20 Hz		
Maximum Continuous Output Current	13mA		

**Insert only provides piezo Z positioning with nanometer accuracy. Requires modification of existing ASI controller or additional MS1 controller. Requires IPZ-4000 series, or PI 545 series, sample holders sold separately.



IPZ Sample Holder Single Slide

35 mm Petri Dish

Accepts a standard 1 x 3 slide, or a 35 mm petri dish
IPZ-4001

Piezo Stages

IPZ-3000 Series Piezo Z-Axis Top Plate Insert and Sample Holders



IPZ Sample Holder Single Slide

50 mm Petri Dish

Accepts a standard 2 x 3 slide, or a 50/60 mm petri dish
IPZ-4002



IPZ Rotating Sample Holder Single Slide

22 mm x 22 mm

Holders accept 22 mm x 22 mm cover slip. The two stainless still spring clips keep sample in place. The integrated ring allows rotating the sample. The flushed IPZ-5001 sample holder sits the cover slip at .25" or 6.4 mm from the base while the recessed IPZ-5003 sits it at .04" or 1 mm.

IPZ-5001 Flushed
IPZ-5003 Recessed



IPZ O-Ring Sample Holder Single Slide

Accepts the ASI I-2450 Autoclavable stainless steel rectangular chamber with replaceable 50 mm x 24 mm coverglass bottom, sealed in place by an O-ring. Outside dimension is 76.0 mm x 50.5 mm (2.99" x 1.99"). Inside diameter at bottom (viewable window) is 42.7 mm x 16.7 mm (1.68" x 0.65"). Height is 10.7 mm (0.42"). I-2450 must be purchased separately
IPZ-4003



IPZ Rotating Sample Holder Single Slide

22 mm x 40 mm

Holders accept 22 mm x 40 mm cover slip. The two stainless still spring clips keep sample in place. The integrated ring allows rotating the sample. The flushed IPZ-5002 sample holder sits the cover slip at .25" or 6.4 mm from the base while the recessed IPZ-5004 sits it at .04" or 1 mm.

IPZ-5002 Flushed
IPZ-5004 Recessed

Piezo Stages

PZM-2000 OEM Manual Stage with Piezo Z-Axis Top Plate



If you do not require automated XY movement, but do require automated Z-axis positioning for acquiring precise Z-axis stacks, then the PZM-2000 is the solution. On select models of inverted microscopes, ASI can modify or exchange your existing OEM stage with a PZM-2000 unit. We can procure a manual OEM stage for you, if necessary.

The PZM-2000 consists of ASI's proven piezo top plate mounted within your existing OEM stage. This requires a completely new top plate be machined for the OEM stage, however, this allows us to provide an elegant solution. The optional PZM-C Controller compliments the ASI PZM-2000 piezo-Z manual microscope stage retrofit. The unit provides an LCD readout of position, an external focusing knob, RS-232 serial control, home and zeroing controls all in a small 6 x 4 inch footprint.

The PZM-2000 has been specifically designed to provide a high resolution, and highly repeatable, means of controlling the Z position of the microscope stage. The XY axes are manually controlled utilizing the original OEM stage controls. The piezo top plate of the stage accepts standard K-size slide inserts that are available for any sample, i.e., slides, Petri dishes, multi-well plates, etc. The slide insert is moved in the Z-axis via a piezo element with a range of 100 μm and with nanometer accuracy (200 μm and 500 μm ranges are also available). By moving the sample in the Z-plane, any objective can be used, eliminating twisting wires or needed spacers as required when a piezo element is put onto a single objective. The piezo stage can be controlled remotely with a 0-10 volt D.C. analog input voltage, or optionally, with a PZM-2000 Controller or a calibrated manual ten-turn potentiometer.

PZM-2000 Features

- Closed-loop control of Z-axes for precise, and highly repeatable focusing
- Nanometer-scale resolution, repeatability, and accuracy
- Proven operation with many popular software packages
- Stage Wings for even more room for attachments

PZM-2000 Options

- X and Y-axis Linear Encoders for high-accuracy positioning, incorporated into the stage plates
- Stage Inserts to hold a variety of slides, dishes, sealed glass chambers, multiwell microplates, perfusers, heaters, and many other special items
- Other lead screw pitches are available, as shown below
- Stage Wings for even more room for attachments

Specifications

XY axis range of travel	Standard OEM Stage
Z axis range of travel ($\pm 5\%$)	150 μm , 300 μm (100 μm and 200 μm versions optional)
Z axis resolution	1.5 nm
Z axis repeatability	± 1 nm
Z axis maximum velocity with settling time	5 mm/sec
(~ 10 ms per move)	
Z axis resonant frequency (unloaded)	> 1 KHz
Z axis top plate maximum load	500 grams
Z axis top plate stiffness ($\pm 20\%$)	3 N/ μm
Z axis top plate in-plane tilt (typical)	10 μrad

Piezo Stages

PZM-2000 OEM Manual Stage with Piezo Z-Axis Top Plate

ADEPT Piezo Controller Specifications

Specification	PZ-2150FT	PZ-2300FT	PZ-2500FT
Piezo Travel Range ($\pm 5\%$)	150 μm	300 μm	500 μm
Piezo smallest move / resolution*	2.2 nm	4.5 nm	7.6 nm
Maximum Load for full range travel	2Kg	1Kg	1Kg
Transient Response time**	11 – 15 ms		
External Analog input (BNC)	0 to 10 Volts		
Maximum Input Frequency	20 Hz		
Maximum Continuous Output Current	13mA		

**Time taken to travel 10%-90% for moves below 30% travel range with 600 grams load.

*In external input mode, use of a higher bit DAC will increase resolution. For example a 0-10 analog voltage from the DAC results in the following:

PZ-2150FT		
External Analog input	Steps	Resolution
16 Bit DAC	65536	2.2 nm
17 Bit DAC	131075	1.1 nm
18 Bit DAC	262144	0.55 nm

Part Numbers

PZM-2150: Manual piezo stage. Only available for certain models of microscopes, and requires that the customers existing OEM stage be exchanged for PZM. Provides 150 μm of Z travel.

PZM-2300: Manual piezo stage. Only available for certain models of microscopes, and requires that the customers existing OEM stage be exchanged for PZM. Provides 300 μm of Z travel.

PZM-2500: Manual piezo stage. Only available for certain models of microscopes, and requires that the customers existing OEM stage be exchanged for PZM. Provides 500 μm of Z travel.



Piezo Stages

PZMU-2000 OEM Series Piezo-Z Top Plate

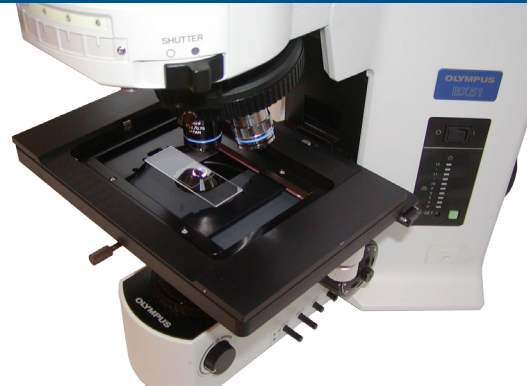

The PZMU-2000 is a precise piezo Z-axis stage that can be attached to the top of a microscope's existing XY stage or be used in stand-alone applications. On select models of microscopes, ASI can mount a PZMU-2000 to an OEM stage. We can procure a manual OEM stage for you if necessary.

The PZMU-2000 consists of ASI's proven piezo-Z top plate mounted within a stand-alone housing. This system can be mounted to any horizontal surface, including on top of a manual XY stage of an upright microscope. The optional MS1-PZM Controller compliments the ASI PZMU-2000, providing an LCD readout of position, an external focusing knob, RS-232 serial control, home and zeroing controls all in a small 6 x 4 inch (152 x 102 mm) footprint.

The PZMU-2000 has been specifically designed to provide a high resolution, and highly repeatable, means of controlling the Z position of a manual microscope stage. The XY axes would remain manually controlled by the original OEM stage controls. The PZMU-2000 accepts standard K-size slide inserts that are available for any sample, i.e., slides, Petri dishes, multi-well plates, etc. The slide insert is moved in the Z-axis via a piezo element with a range of 100 µm and with nanometer accuracy (200 µm and 500 µm ranges are also available). By moving the sample in the Z-plane, any objective can be used, eliminating twisting wires or needed spacers as required when a piezo element is put onto a single objective. The piezo stage can be controlled remotely with a 0-10 volt D.C. analog input voltage, or optionally, with a PZM-2000 Controller. Stages, controllers and top plates are sold separately.

Features

- Closed-loop control of Z-axis for precise and highly repeatable focusing
- Nanometer-scale resolution, repeatability, and accuracy
- Proven operation with many popular software packages

PZMU-2000 Specifications

(XY axis range of travel)	(Standard OEM Stage)
Z axis range of travel (± 5%)	100 µm (200 µm and 500 µm versions optional)
Z axis resolution	1.5 nm
Z axis repeatability	± 1 nm
Z axis maximum velocity with settling time	5 mm/sec (~ 10 ms per move)
Z axis resonant frequency (unloaded)	> 1 KHz
Z axis top plate maximum load	500 grams
Z axis top plate stiffness (± 20%)	3 N/µm
Z axis top plate in-plane tilt (typical)	10 µrad
Dimensions (L x W x H)	242 x 176 x 19 mm (9½" x 7" x ¾")

MS1-PZM Controller Specifications

Computer piezo control	RS-232 Serial
Manual piezo control	Front panel knob
External piezo control	0 – 10 VDC Pass-thru
Position information (regardless of control)	LCD Display
Control buttons	"Home" and "Zero"
Power module	12 VDC

Piezo Stages

PZMU-2000 OEM Series Piezo-Z Top Plate

ADEPT Piezo Controller Specifications

Specification	PZ-2150FT	PZ-2300FT	PZ-2500FT
Piezo Travel Range (+/- 5%)	150 µm	300 µm	500 µm
Piezo smallest move / resolution*	2.2 nm	4.5 nm	7.6 nm
Maximum Load for full range travel	2Kg	1Kg	1Kg
Transient Response time**	11 – 15 ms		
External Analog input (BNC)	0 to 10 Volts		
Maximum Input Frequency	20 Hz		
Maximum Continuous Output Current	13mA		

**Time taken to travel 10%-90% for moves below 30% travel range with 600 grams load.

*In external input mode, use of a higher bit DAC will increase resolution. For example a 0-10 analog voltage from the DAC results in the following:

PZ-2150FT		
External Analog input	Steps	Resolution
16 Bit DAC	65536	2.2 nm
17 Bit DAC	131075	1.1 nm
18 Bit DAC	262144	0.55 nm

Part Numbers

PZMU-2150, 2300, 2500: Piezo Z manual top plate option for upright microscope.

PZM-C: ASI manual piezo controller: Small 6" x 4" unit with focus knob and LCD display. Allows for RS232 control of piezo stage as well as analog voltage (0-10V) control.

MS1: Single axis controller

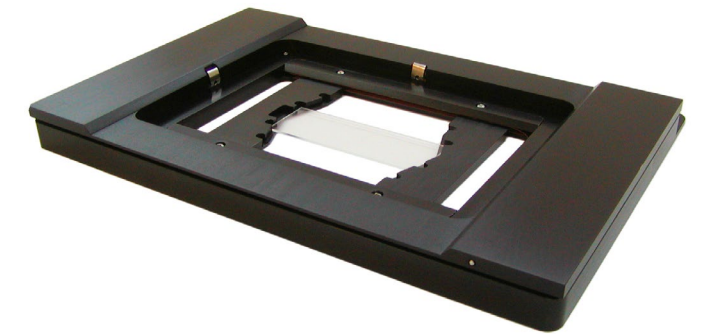

Piezo Stages

PZU-2000 XYZ Automated Stage with Piezo Z-Axis Top Plate

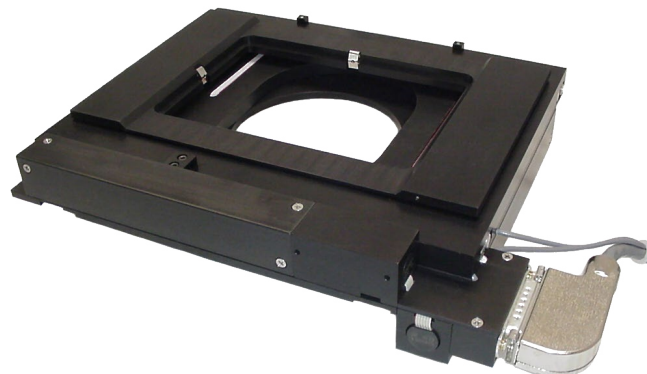

The PZU-2000 XYZ stage has been specifically designed to provide a high resolution, and highly repeatable, means of controlling the X, Y, and Z position of the microscope stage. The XY axes derive their precise control through the use of closed-loop DC servomotors employing high-resolution rotary encoders for positioning feedback. By using closed-loop control for the stage position, there is no chance that the stage will become lost, as can occur with open-loop micro-stepped stages after a number of moves and direction changes. The XY stage utilizes crossed-roller slides, high-precision lead screws, and zero-backlash miniature geared DC servomotors for smooth and accurate motion. The top plate of the stage accepts standard K-size slide inserts that are available for any sample, i.e., slides, petri dishes, multi-well plates, etc. The slide insert is moved in the Z-axis via a piezo element with a range of 150 μm with nanometer accuracy (300 μm and 500 μm range is also available). By moving the sample in the Z-plane, any objective can be used, eliminating twisting wires or needed spacers as required when a piezo element is put onto a single objective. The microprocessor-controlled MS-2000 control unit provides for RS-232 and USB communication with a host computer for control of the XYZ axis.

Stages, controllers and top plates are sold separately.

Features

- Closed-loop control of the X, Y, and Z-axes for precise positioning and highly repeatable focusing
- Wide dynamic speed range with adjustable trapezoidal move profiles
- Smooth adjustable dual-range joystick control
- Backlit LCD display shows X, Y, and Z coordinates
- "Zero" and "Home" button for simple stand-alone operations
- Compact ergonomic tabletop control unit size is 6" D x 9" W x 3" H (9 cm x 23 cm x 1 1/2 cm)
- Proven operation with many popular software packages

PZU-2000 Options

- XY axes Linear Encoders for high-accuracy positioning. Linear encoder resolution is 10 nm, with a scale accuracy of 0.3 μm per 10mm and 3 μm per 100 mm. Positioning resolution at sample is < 50 nm.
- Auto Focus (requires NTSC or PAL composite video signal).
- ASI's proven line of Z-axis drives can also be added to the fine focus shaft of the microscope to provide Z-axis positioning with a resolution of 50 nm throughout the range of the microscope's travel. The piezo unit can then be used for fast and accurate Z-axis positioning to any point within the range of travel.
- Other lead screw pitches are available for faster XY translation, or for more precise positioning when using standard rotary encoders.

Specifications for Standard Configuration

XY axis range of travel	114 mm x 100 mm
XY axis resolution (encoder step)	0.088 μm
XY axis lead screw accuracy	0.25 $\mu\text{m}/\text{mm}$
XY axis RMS repeatability	< 0.7 μm
XY axis maximum velocity	7 mm/sec
Z axis range of travel	100 μm (175 μm version optional)
Z axis resolution	1.5nm
Z axis repeatability	± 1 nm
Z axis maximum velocity with setting time	5 mm/sec (~10 ms per move)
Z axis resonant frequency (unloaded)	> 1 KHz
Z axis top plate maximum load	500 grams
Z axis top plate stiffness (+/- 20%)	3 N/ μm
Z axis top plate in-plane tilt (typical)	10 μrad

Piezo Stages

PZU-2000 XYZ Automated Stage with Piezo Z-Axis Top Plate

ADEPT Piezo Controller Specifications

Specification	PZ-2150FT	PZ-2300FT	PZ-2500FT
Piezo Travel Range (+/- 5%)	150 μm	300 μm	500 μm
Piezo smallest move / resolution*	2.2 nm	4.5 nm	7.6 nm
Maximum Load for full range travel	2Kg	1Kg	1Kg
Transient Response time**	11 – 15 ms		
External Analog input (BNC)	0 to 10 Volts		
Maximum Input Frequency	20 Hz		
Maximum Continuous Output Current	13mA		

**Time taken to travel 10%-90% for moves below 30% travel range with 600 grams load.

*In external input mode, use of a higher bit DAC will increase resolution. For example a 0-10 analog voltage from the DAC results in the following:

PZ-2150FT		
External Analog input	Steps	Resolution
16 Bit DAC	65536	2.2 nm
17 Bit DAC	131075	1.1 nm
18 Bit DAC	262144	0.55 nm

Part Number

PZU-2150: Piezo Z top plate option for upright microscopes. Provides 150 μm of Z travel.

PZU-2300: Piezo Z top plate option for upright microscopes. Provides 300 μm of Z travel.

PZU-2500: Piezo Z top plate option for upright microscopes. Provides 500 μm of Z travel.

Product Compatibility

- Leica
- Nikon
- Olympus
- Zeiss



Compact Stages

3D/4D Compact Stage

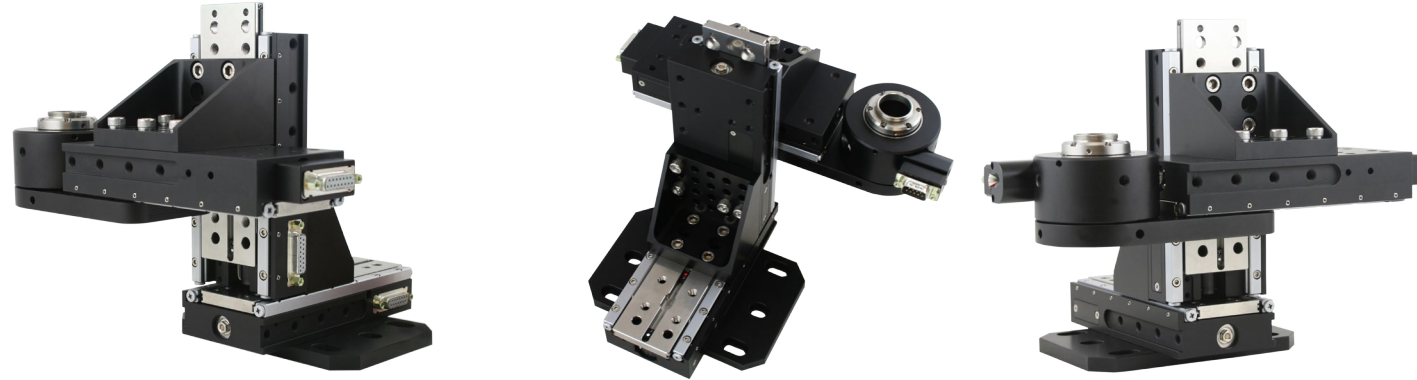

ASI's compact 3D/4D stage is a precise motorized motion control system designed to move samples around fixed optics. It incorporates three ASI linear stages and an optional motorized rotating stage employed for a theta axis. The linear stages comprising the XYZ elements offer travel options of 25, 50, 100, or 200 mm and each axis can be chosen separately. The linear stages derive smooth and accurate motion from closed-loop DC servomotors, crossed-roller bearings, high-precision lead screws, and high-resolution encoders for positioning feedback. Like other ASI stages, these can move uniformly at extremely slow speeds for in-motion acquisition. All the stages offer various speed/accuracy options for a more customized 3D/4D system. The stage elements are rigidly attached together, and usually mounted to a breadboard via an adapter plate.

ASI offers a variety of controllers that are compatible with this stage, including the MS-2000 and the modular Tiger controller. All provide automatic backlash correction, and can communicate with a host computer by RS-232 or USB connection.

Leadscrew Options

Leadscrew Pitch Options	Rotary Encoder Resolution	Maximum Speed
25.40 mm (Ultra-coarse)	88 nm	28 mm/sec
12.70 mm (Super-coarse)	44 nm	14 mm/sec
6.35mm (Standard)	22 nm	7 mm/sec
1.59 mm (Fine)	5.5 nm	1.75 mm/sec
0.653 mm (Extra-Fine)	2.2 nm	0.7 mm/sec

**Shown with rotary encoder and 6.35 mm pitch lead screw*

Compact Stages

3D/4D Compact Stage

Specifications

Specifications	Dimensions
Encoder Resolution*	5.5 nm
with Linear Encoder	10 nm
RMS repeatability (Typical)*	< 0.7 μ m
with Linear Encoder (Typical)	200 nm
Leadscrew Accuracy	0.25 μ m/mm
with Linear Encoder	\pm 3 μ m/length of scale
Maximum Velocity*	1.75 mm/sec
Range of Travel*	25 mm (1") to 100 mm (4")

** With 1.59 mm pitch (16 TPI) Lead screw*



Inverted Stages

MS-2000 Flat-Top Automated Stage

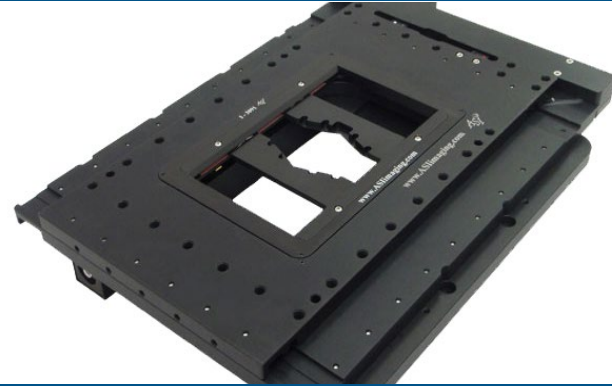

The MS-2000 Flat Top XY stage has been specifically designed to provide a high resolution, and highly repeatable, means of controlling the X, Y position of the microscope stage. The stage can be used in conjunction with ASI's proven line of Z-axis motor drives, each custom fitted to the microscope, for complete X, Y, and Z positioning. All axes derive their precise control through the use of closed-loop DC servomotors employing high-resolution rotary encoders for positioning feedback. By using closed-loop control of the stage position, there is no chance that the stage will become lost, as can occur with open-loop micro-stepped stages after a number of moves and direction changes. The MS-2000 XY stage utilizes crossed-roller slides, a high-precision lead screw, and zero-backlash miniature geared DC servomotors for smooth and accurate motion. The microprocessor-controlled MS-2000 control unit provides for RS-232 and USB communication with a host computer.

MS-2000 Options

- Piezo Top Plates with Z ranges of 150, 300, and 500 nm
- X and Y axes Linear Encoders for high-accuracy positioning
- Larger stage top plate for attachment of micromanipulators, microinjectors, etc.
- Stage Wings for even more room for attachments
- Autofocus for stages with ASI Z-axis drives (requires NTSC, PAL, or S-Video analog signal)
- Other lead screw pitches are available

Features

- Closed-loop DC servo control of the X and Y axes for precise positioning and highly repeatable focusing
- Wide dynamic speed range with XY Joystick Control
- Utilizes ASI's proven Z-axis drives
- Z-axis clutch for easy switching between manual and motor-driven focus control
- Backlit LCD display shows X, Y, and Z coordinates
- "Zero" and "Home" button for simple stand-alone operations
- Compact ergonomic tabletop control unit size is 6" D x 9" W x 3" H (9 cm x 23 cm x 16½ cm)
- Microprocessor control with RS-232 serial and USB communications
- Proven operation with many popular software packages
- Travel range will scan full well plate in most circumstances

Specifications for Standard Configuration

XY axis range of travel	120 mm x 75 mm
XY axis resolution (encoder step)	22 nm
XY axis RMS repeatability	< 700 nm
XY axis maximum velocity	7 mm /sec
Max Recommended Load (*higher loads available upon request)	5kg

**Shown with 6.35 mm pitch Lead Screw*

Inverted Stages

MS-2000 Flat-Top Automated Stage

Lead Screw Options

Lead Screw Pitch Options	Rotary Encoder Resolution	Maximum Speed
25.40 mm (Ultra-coarse)	88 nm	28 mm/sec
12.70 mm (Super-coarse)	44 nm	14 mm/sec
6.35 mm (Standard)	22 nm	7 mm/sec
1.59 mm (Fine)	5.5 nm	1.75 mm/sec
0.635 mm (Extra-fine)	2.2 nm	0.7 mm/sec

Linear Encoder Options

Axis	Resolution	Scale Accuracy
XY	10 nm	± 3 µm per length of scale
Z (12 mm and 25 mm stroke)	50 nm	0.025 µm per mm

Product Compatibility

- Leica
- Nikon
- Olympus
- Zeiss

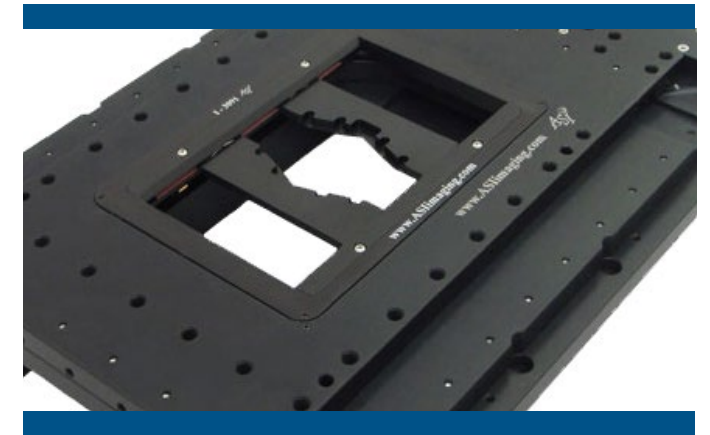

Inverted Stages

MS-2000 XY Automated Stage

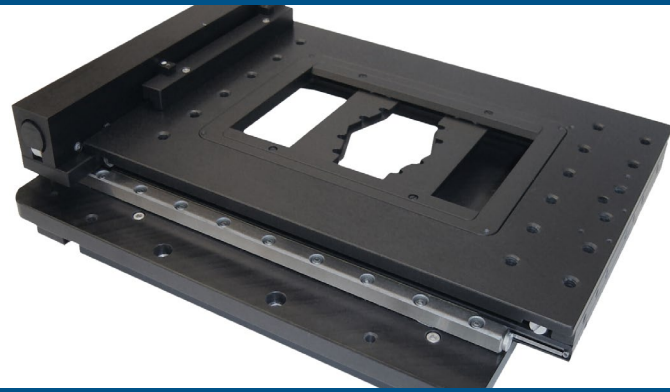

The MS-2000 XYZ stage has been specifically designed to provide a high resolution, and highly repeatable, means of controlling the X, Y, and Z position of the microscope stage. All axes derive their precise control through the use of closed-loop DC servomotors employing high-resolution rotary encoders for positioning feedback. By using closed-loop control of the stage position, there is no chance that the stage will become lost, as can occur with open-loop micro-stepped stages after a number of moves and direction changes. The MS-2000 XY stage utilizes crossed-roller slides, a high-precision lead screw, and zero-backlash miniature geared DC servomotors for smooth and accurate motion. The Z-axis drive also uses ASI's proven line of closed-loop motor drives, each custom fitted to the microscope. The microprocessor-controlled MS-2000 control unit provides for RS-232 and USB communication with a host computer.

Features

- Closed-loop DC servo control of the X and Y axes for precise positioning and highly repeatable focusing
- Wide dynamic speed range with XY joystick control
- Utilizes ASI's proven Z-axis drives
- Z-axis clutch for easy switching between manual and motor-driven focus control
- Backlit LCD display shows X, Y, and Z coordinates
- "Zero" and "Home" button for simple stand-alone operations
- Compact ergonomic tabletop control unit size is 6" D x 9" W x 3" H (9 cm x 23 cm x 16½ cm)
- Microprocessor control with RS-232 serial and USB communications
- Proven operation with many popular software packages

MS-2000 Options

- Linear Encoders for high-accuracy positioning
- Larger stage top plate for attachment of micromanipulators, microinjectors, etc.
- Stage Wings for even more room for attachments
- Autofocus for stages with ASI Z-axis drives (requires NTSC, PAL, or S-Video analog signal)
- Other lead screw pitches are available

Specifications for Standard Configuration

XY axis range of travel	120 mm x 110 mm
XY axis resolution (encoder step)	22 nm
XY axis RMS repeatability	< 700 nm
XY axis maximum velocity	7 mm /sec

**Shown with 6.35 mm pitch Lead Screw*

Inverted Stages

MS-2000 XY Automated Stage

Lead Screw Options

Lead Screw Pitch Options	Rotary Encoder Resolution	Maximum Speed
25.40 mm (Ultra-coarse)	88 nm	28 mm/sec
12.70 mm (Super-coarse)	44 nm	14 mm/sec
6.35 mm (Standard)	22 nm	7 mm/sec
1.59 mm (Fine)	5.5 nm	1.75 mm/sec
0.635 mm (Extra-fine)	2.2 nm	0.7 mm/sec

Linear Encoder Options

Axis	Resolution	Scale Accuracy
XY	10 nm	± 3 µm per length of scale

Product Compatibility

- Leica
- Nikon
- Olympus
- Zeiss



Inverted Stages

MS-2500-Ti XY Flat-Top Extended Travel Stage

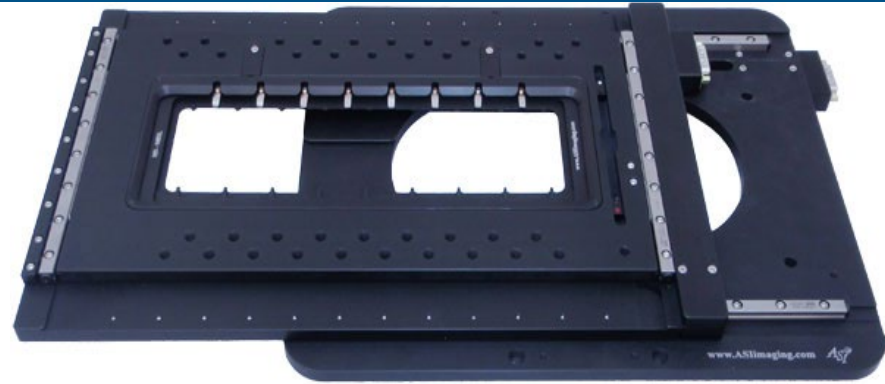

The MS-2500-Ti XY low-profile stage has been specifically designed to provide 100 mm (4") of Y-axis travel with an extended 250 mm (10") of X-axis travel. This extended travel makes for easy robotic loading or for holding more samples per stage insert. The MS-2500 stage accepts either standard 160x110 or wide 283x110 stage inserts. Total stage thickness is only 54.1 mm (2.13"), and only 29.3 mm (1.16") from its flat obstruction-free top to its bottom mounting surface.

The high resolution, and highly repeatable, stage derive its precise control through the use of closed-loop DC servomotors employing high-resolution rotary encoders for positioning feedback. Optional linear encoders improve repeatability to less than 300 nm (typical) compared to the standard rotary encoder's 700 nm (typical) repeatability rating.

By using closed-loop control of the stage position, there is no chance that the stage will become lost, as can occur with open-loop micro-stepped stages after a number of moves and direction changes. The MS-2500-Ti XY stage utilizes crossed-roller slides, a high-precision lead screw, and zero-backlash miniature geared DC servomotors for smooth and accurate motion. The Z-axis drive also uses ASI's proven line of closed-loop motor drives, each custom fitted to the microscope. The microprocessor-controlled MS-2000 control unit provides for RS-232 and USB communication with a host computer.

MS-2500-Ti Options

- X and Y-axis Linear Encoders for high-accuracy positioning, incorporated into the stage plates
- Stage Inserts to hold a variety of slides, dishes, sealed glass chambers, multiwell microplates, perfusers, heaters, and many other special items
- Other lead screw pitches are available
- Stage Wings for even more room for attachments

MS-2500-Ti Features

- Obstruction-free flat top
- Thin profile: 29.3 mm (1.16") from mounting surface to top
- Closed-loop DC servo control of the X and Y-axes for precise positioning and highly repeatable focusing
- Wide dynamic speed range with XY joystick control
- Can be used with ASI's proven Z-axis drives
- Backlit LCD display shows axes' coordinates
- "Zero" and "Home" button for simple stand-alone operations
- Compact ergonomic tabletop control unit size is 9 cm (H) x 23 cm (W) x 16½ cm (D) (3" x 9" x 6")
- Microprocessor control with RS-232 serial and USB communications
- Proven operation with many popular software packages
- Suitable for stand-alone, OEM, and specialty applications as well

Inverted Stages

MS-2500-Ti XY Flat-Top Extended Travel Stage

Specifications for Standard Configuration

XY axis range of travel	250 mm x 75 mm
XY axis resolution	22 nm (typical)
XY axis RMS repeatability	< 700 nm (typical)
XY axis maximum velocity	7 mm/sec

*Shown with 6.35mm pitch lead screws

Lead Screw Options

Lead Screw Pitch Options	Rotary Encoder Resolution	Maximum Speed
25.40 mm (Ultra-coarse)	88 nm	28 mm/sec
12.70 mm (Super-coarse)	44 nm	14 mm/sec
6.35 mm (Standard)	22 nm	7 mm/sec
1.59 mm (Fine)	5.5 nm	1.75 mm/sec
0.635 mm (Extra-fine)	2.2 nm	0.7 mm/sec

* Standard Lead Screw Accuracy is 0.25 µm per millimeter

Linear Encoder Options

Axis	Resolution	Scale Accuracy
XY	10 nm	± 3 µm per length of scale

Part Numbers

Ti-2500: XY stage 250 x 100 mm of travel for scanning a wide range of samples. Extended X axis travel makes for easy robotic loading. Stage is closed loop with rotary encoders.

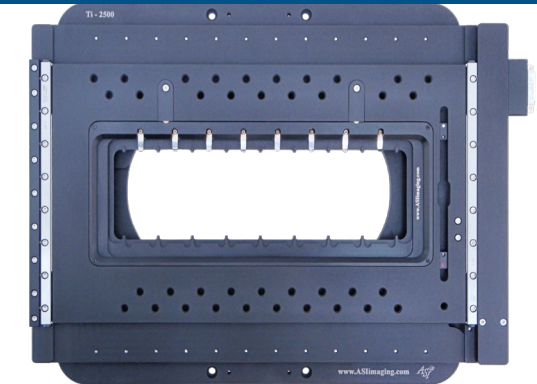

Contact ASI for assistance to discuss stage configuration

Inverted Stages

MS-2500-Dmi8 XY Flat-Top Extended Travel Stage



The MS-2500-Dmi8 Stage has been designed to fit the Leica Dmi8 and Dmi6000. It is a low profile flat top designed with 250 mm of X-Axis and 110 mm Y-Axis travel (Microscope Limited). The MS-2500-Dmi8 stage accepts either 160 x 110 or 283 x 110 stages inserts. This System has high resolution, high repeatability, and precise motion. Through the use of closed-loop DC servo motors employing high-resolution rotary encoders for positioning feedback, the MS-2500-Dmi8 has the ability to use three of the major linear encoder manufacturers to improve repeatability to less than 300 nm (typical) compared to the standards rotary encoders 200 nm (typical) repeatability rating.

By using closed-loop control of the stage position, there is no chance that the stage will become lost, as can occur with open-loop micro-stepped stages after a number of moves and direction changes. The MS-2500 XY stage utilizes crossed-roller slides, a high-precision lead screw, and zero-backlash miniature geared DC servomotors for smooth and accurate motion. The Z-axis drive also uses ASI's proven line of closed-loop motor drives, each custom fitted to the microscope. The microprocessor-controlled MS-2000 control unit provides for RS-232 and USB communication with a host computer.

MS-2500-Dmi8 Options

- X and Y-axis Linear Encoders for high-accuracy positioning, incorporated into the stage plates
- Stage Inserts to hold a variety of slides, dishes, sealed glass chambers, multiwell microplates, perfusers, heaters, and many other special items
- Other lead screw pitches are available

MS-2500-Dmi8 Features

- Obstruction-free flat top / Rigid top plate design
- Thin profile: 38.3 mm (1.51") from mounting surface to top
- Closed-loop DC servo control of the X and Y-axes for precise positioning and highly repeatable focusing
- Wide dynamic speed range with XY joystick control
- Can be used with ASI's proven Z-axis drives
- Backlit LCD display shows axes' coordinates
- "Zero" and "Home" button for simple stand-alone operations
- Compact ergonomic tabletop control unit size is 9 cm (H) x 23 cm (W) x 16½ cm (D) (3" x 9" x 6")
- Microprocessor control with RS-232 serial and USB communications
- Proven operation with many popular software packages
- Suitable for stand-alone, OEM, and specialty applications as well

Inverted Stages

MS-2500-Dmi8 XY Flat-Top Extended Travel Stage

Specifications for Standard Configuration

XY axis range of travel	250 mm x 75 mm
XY axis resolution*	22 nm (typical)
XY axis RMS repeatability*	< 700 nm (typical)
XY axis maximum velocity*	7 mm/sec

*Shown with 6.35mm pitch lead screws

Lead Screw Options

Lead Screw Pitch Options	Rotary Encoder Resolution	Maximum Speed
25.40 mm (Ultra-coarse)	88 nm	28 mm/sec
12.70 mm (Super-coarse)	44 nm	14 mm/sec
6.35 mm (Standard)	22 nm	7 mm/sec
1.59 mm (Fine)	5.5 nm	1.75 mm/sec
0.635 mm (Extra-fine)	2.2 nm	0.7 mm/sec

Standard Lead Screw Accuracy is 0.25 µm per millimeter

Linear Encoder Options

Axis	Resolution	Scale Accuracy
XY	10 nm	± 3 µm per length of scale

Part Numbers

Dmi8-2500: XY stage 250 x 100 mm of travel for scanning a wide range of samples. Extended X axis travel makes for easy robotic loading. Stage is closed loop with rotary encoders.

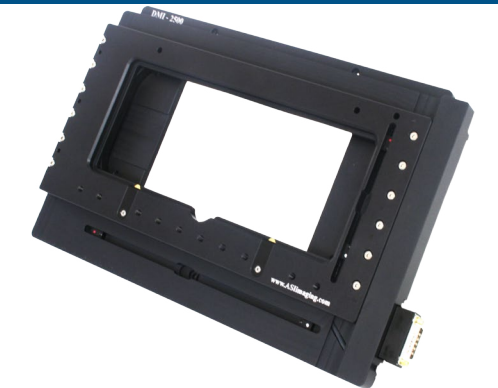

Contact ASI for assistance to discuss stage configuration

Inverted Stages

MS-2500-AV XY Flat-Top Extended Travel Stage



The MS-2500-AV Stage has been designed to fit the Zeiss-Axio Observer. It is a low profile flat top designed with 250 mm of X-Axis and 110 mm Y-Axis travel (Microscope Limited). The MS-2500-AV stage accepts either 160 x110 or 283 x110 stages inserts. This System has high resolution, high repeatability, and precise motion. Through the use of closed-loop DC servomotors employing high-resolution rotary encoders for positioning feedback, the MS-2500-AV has the ability to uses three of the major linear encoder manufactures to improve repeatability to less than 300 nm (typical) compared to the standards rotary encoders 200 nm (typical) repeatability rating.

By using closed-loop control of the stage position, there is no chance that the stage will become lost, as can occur with open-loop micro-stepped stages after a number of moves and direction changes. The MS-2500-AV XY stage utilizes crossed-roller slides, a high-precision lead screw, and zero-backlash miniature geared DC servomotors for smooth and accurate motion. The Z-axis drive also uses ASI's proven line of closed-loop motor drives, each custom fitted to the microscope. The microprocessor-controlled MS-2000 control unit provides for RS-232 and USB communication with a host computer.

MS-2500-AV Features

- Obstruction-free flat top / Rigid top plate design
- Thin profile: 34.5 mm (1.36") from mounting surface to top
- Closed-loop DC servo control of the X and Y-axes for precise positioning and highly repeatable focusing
- Wide dynamic speed range with XY joystick control
- Can be used with ASI's proven Z-axis drives
- Backlit LCD display shows axes' coordinates
- "Zero" and "Home" button for simple stand-alone operations
- Compact ergonomic tabletop control unit size is 9 cm (H) x 23 cm (W) x 16½ cm (D) (3" x 9" x 6")
- Microprocessor control with RS-232 serial and USB communications
- Proven operation with many popular software packages
- Suitable for stand-alone, OEM, and specialty applications as well

MS-2500-AV Options

- X and Y-axis Linear Encoders for high-accuracy positioning, incorporated into the stage plates
- Stage Inserts to hold a variety of slides, dishes, sealed glass chambers, multiwell microplates, perfusers, heaters, and many other special items
- Other lead screw pitches are available

Inverted Stages

MS-2500-AV XY Flat-Top Extended Travel Stage

Specifications for Standard Configuration

XY axis range of travel	250 mm x 75 mm
XY axis resolution*	22 nm (typical)
XY axis RMS repeatability*	< 700 nm (typical)
XY axis maximum velocity*	7 mm/sec

*Shown with 6.35mm pitch lead screws

Lead Screw Options

Lead Screw Pitch Options	Rotary Encoder Resolution	Maximum Speed
25.40 mm (Ultra-coarse)	88 nm	28 mm/sec
12.70 mm (Super-coarse)	44 nm	14 mm/sec
6.35 mm (Standard)	22 nm	7 mm/sec
1.59 mm (Fine)	5.5 nm	1.75 mm/sec
0.635 mm (Extra-fine)	2.2 nm	0.7 mm/sec

Standard Lead Screw Accuracy is 0.25 µm per millimeter

Linear Encoder Options

Axis	Resolution	Scale Accuracy
XY	10 nm	± 3 µm per length of scale

Part Numbers

AV-2500 LE: XY stage 250 x 100 mm of travel for scanning a wide range of samples. Extended X axis travel makes for easy robotic loading. Stage is closed loop with rotary encoders.

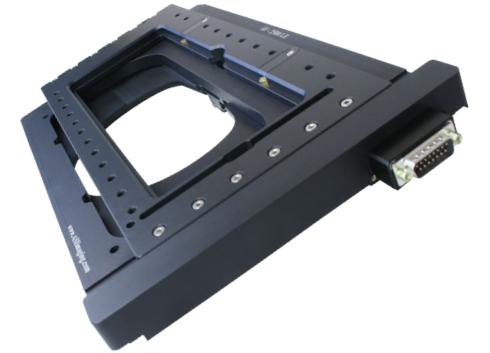

Inverted Stages

US-2000 Ultra Stable Flat Top XYZ Automated Stage

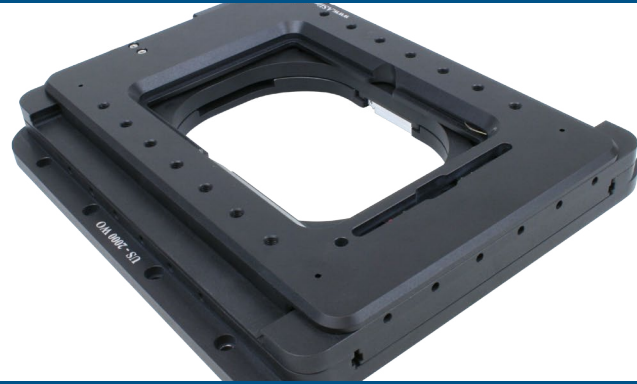

The US-2000 Flat Top XY stage has been specifically designed to provide an ultra-stable, high resolution, and highly repeatable means of controlling the X, Y position of the microscope stage for superior resolution microscopy applications. The stage can be used in conjunction with ASI's proven line of Z-axis motor drives, each custom fitted to the microscope for complete XYZ positioning. All axes derive their precise control through the use of closed loop DC servomotors employing high resolution rotary encoders for positioning feedback. For ultra high precision Z focusing piezos can be embedded within the top plate of the stage in travel ranges of 150, 300, or 500 microns. The US-2000 XY stage utilizes crossed-roller slides, a high precision lead screw, and zero backlash miniature geared DC servomotors for smooth and accurate motion. XY travel ranges from 25mm to 120mm are available. To minimize thermal drift it is best to choose the 25mm travel range as it uses a smaller lead screw to reduce thermal variations at the sample. With the optional linear encoders and 0.635mm pitch lead screws resolutions of 2.5 nm with true optical resolutions of 10nm at the sample are available. The micro-processor controlled MS-2000 control unit provides for RS-232 and USB communication with a host computer. Systems are available for all standard research grade microscopes and OEM applications.

US-2000 Options

- Piezo top plates with Z ranges of 150, 300 and 500 μm
- Larger stage top plate for attachment of micromanipulators, microinjectors, etc...
- Stage wings for even more room for attachments
- Autofocus for stages with ASI Z-axis drives (requires NTSC, PAL, or S-Video analog signal)
- Other lead screw pitches are available

US-2000 Features

- Closed loop DC servo control of the X, Y, and Z-axes for precise positioning and highly repeatable focusing
- Wide dynamic speed range with XY joystick
- Utilizes ASI's proven Z-axis drives
- Z-axis clutch for easy switching between manual and motor driven focus control
- Backlit LCD display shows X, Y, and Z coordinates
- "Zero" and "Home" buttons for simple stand-alone operations
- Compact, ergonomic tabletop control unit size is 6" D x 9" W x 3" H (9 cm x 23 cm x 16.5 cm)
- Microprocessor control with RS-232 serial and USB communications
- Travel Range will scan full well plate in most circumstances
- Proven operation with many popular software packages

Specifications for Standard Configuration

XY axis range of travel	25 mm x 25 mm up to 120 mm x 75 mm
XY axis resolution (encoder step)	2.5 nm (10nm at optical axis)
XY axis RMS repeatability	< 200 nm
XY axis maximum velocity (dependent on lead screw pitch option)	0.635 mm/sec
Z axis resolution with optional piezo top plate	2.2nm with 16 bit DAC 1.1nm with 17 bit DAC
Z axis repeatability with optional piezo top plate	+/- 2 nm
Z axis maximum velocity with optional piezo top plate	~ 10 ms for most moves
Max recommended load	1 kg

Inverted Stages

US-2000 Ultra Stable Flat Top XYZ Automated Stage

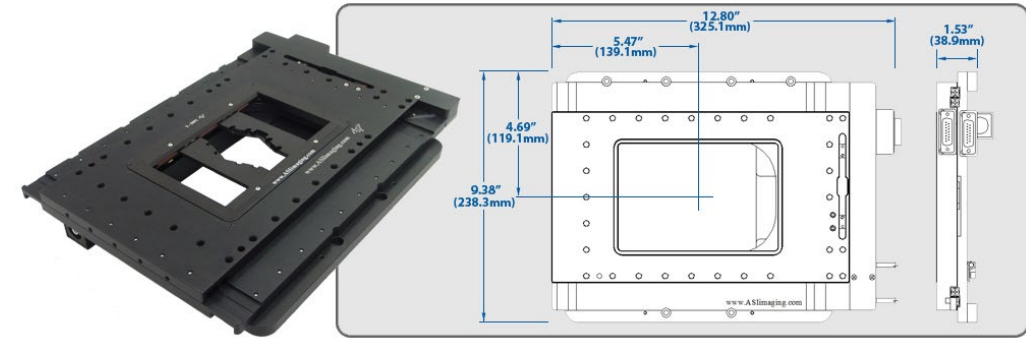

Lead Screw Options

Lead Screw Pitch Options	Rotary Encoder Resolution	Maximum Speed
25.40 mm (Ultra-coarse)	88 nm	28 mm/sec
12.70 mm (Super-coarse)	44 nm	14 mm/sec
6.35 mm (Standard)	22 nm	7 mm/sec
1.59 mm (Fine)	5.5 nm	1.75 mm/sec
0.635 mm (Extra-fine)	2.2 nm	0.7 mm/sec

* Standard Lead Screw Accuracy is 0.25 μm per millimeter

Large Stages

Large Stages

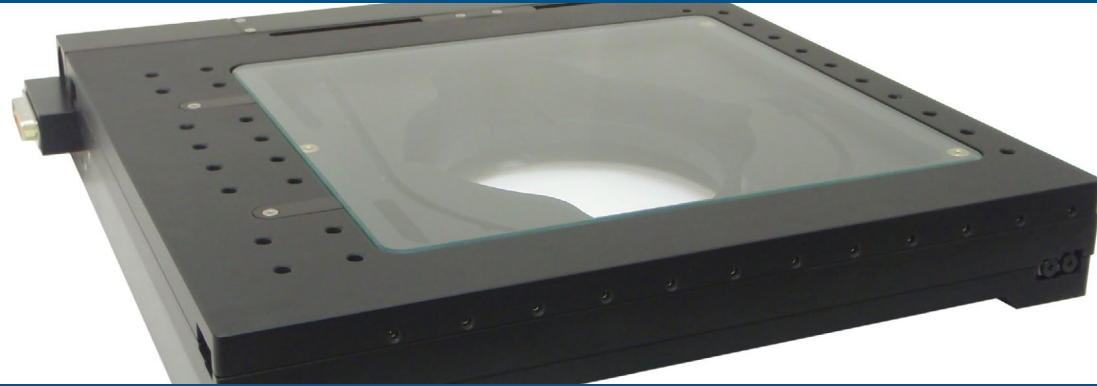

ASI offers larger custom stages in addition to the standard biological stages that we stock. Typically the standard microscope stages that ASI supplies for biological have an XY travel of 4" x 4" or 100 mm x 100 mm. While these travel distances work well for biological applications, larger travel distances are required for semiconductor inspection and other demanding applications. For these applications, ASI offers stages in the standard sizes shown below. By utilizing ASI's proven line of closed loop DC servo motor electronics, these larger stages can be configured with a wide range of speed and resolution options.

Specifications

Part Number/ Series	XY Length of Travel	Type of Feedback Available
M-6000	6" x 6" 150 mm x 150 mm	Rotary or Linear Encoders
M-8000	8" x 8" 200 mm x 200 mm	Rotary or Linear Encoders
M-10000	10" x 10" 250 mm x 250 mm	Rotary or Linear Encoders
M-12000	12" x 12" 300 mm x 300 mm	Rotary or Linear Encoders

Large Stages

MS-8000 XY Automated Stage

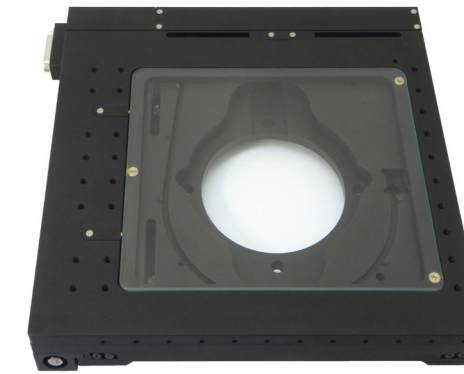

The MS-8000 stage is suited to use with large industrial inspection microscopes such as the Nikon L200/300 series or Olympus MX51/61 series. The open frame allows for transmitted light illumination. The stage can be supplied with either a glass plate insert, or a variety of large format stage inserts, including a vacuum wafer chuck for semiconductor inspection.

The DC servo motor stage is compatible with either small precision anti-backlash gear-head motors or larger spur-head motors for faster speeds. The stage is also compatible with optional high accuracy linear encoders.

Features

- Closed-loop DC servo control for precise positioning and highly repeatable focusing
- Wide dynamic speed range with XY joystick control
- Backlit LCD display shows X, Y, and Z coordinates
- "Zero" and "Home" button for simple stand-alone operations
- Compact ergonomic tabletop control unit size is 6" D x 9" W x 3" H
- Microprocessor control with RS-232 serial and USB communications
- Proven operation with many popular software packages

Linear Encoder Options

Axis	Resolution	Scale Accuracy
XY	10 nm	± 3 μm per length of scale

Lead Screw Options with 141:1 Anti-Backlash Gear-Head Motors

Lead Screw Pitch Options	Encoder Resolution	Maximum Speed	Repeatability
1/4"	22 nm	6.4 mm/sec	0.8 μm
1/2"	44 nm	12 mm/sec	1.6 μm
1"	88 nm	24 mm/sec	3.5 μm

Lead Screw Options with 3.7:1 Gear Head Motors

Lead Screw Pitch Options	Encoder Resolution	Maximum Speed	Repeatability
1/16"	210 nm	30 mm/sec	4.5 μm
1/4"	0.84 μm	120 mm/sec	8.0 μm
1/2"	1.7 μm	240 mm/sec	15.0 μm

Large Stages

Automated XYZ Gantry Translation Stage

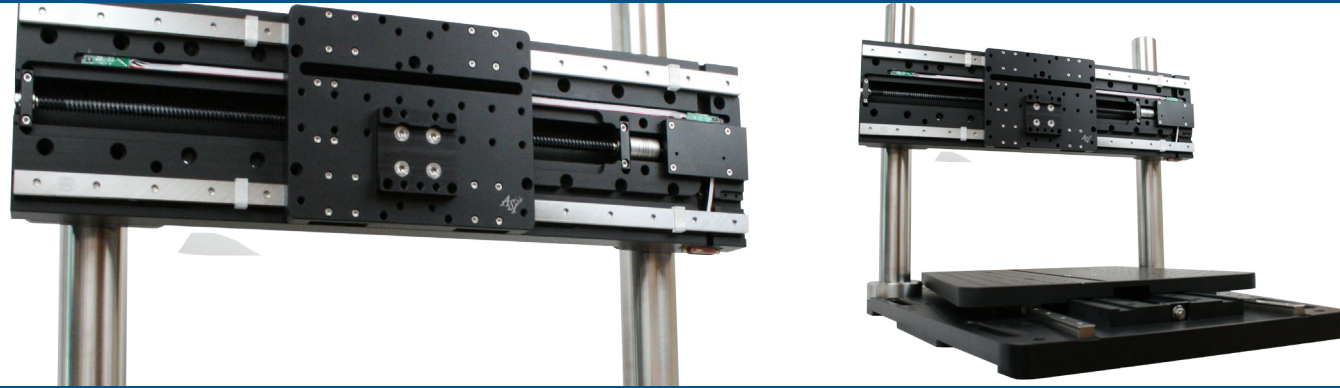

GTS-Series Gantry Translation Stages offer three precision closed-loop DC servo motor linear actuators available in a range of travels. The standard 15-inch unit, shown, allows 380 mm of travel in the X and Y coordinates and 100 mm (4") of travel in the Z axis, with smaller and larger travel ranges available. An optional fourth axis controls the zooming video microscope, shown, available with zoom ranges as high as 16X.

The units utilize precision bearing guide assemblies to provide smooth and accurate movement. The entire stage assembly is precisely machined to demanding tolerances to provide a standard XY resolution of less than 3 microns, with typical bi-directional repeatability better than 5 microns. The X and Y axes have a maximum travel speed of 100 mm (4") per second in the standard configuration, with other speed options available.

The Z axis has a standard resolution of less than 0.1 microns, with typical bi-directional repeatability better than 1 micron. The Z axis has a maximum travel speed of 7 mm (1/4") per second in the standard configuration, with other speed options available.

Linear encoder options are available on all axes to provide resolutions down to 10 nm, with typical repeatability better than 500 nm, and scale accuracy of $\pm 3 \mu\text{m}$ per length of scale.

The GTS can be custom configured with cameras and video microscopes with automated focusing and motorized zoom. A wide array of lighting options are available as well, including coaxial illuminators, ring lights, and the LED light box, shown, with variable intensity and uniform light distribution.

The large number of options available allows the unit to be easily configured for a wide variety of image acquisition, inspection, and 3D positioning and profiling applications.

Features

- Closed-loop DC servo control of the X, Y, and Z axes for precise positioning
- Wide dynamic speed range with adjustable trapezoidal move profiles
- Electronic torque limit on drives for "built-in" limit protection
- Hall-effect limit sensors on X, Y, and Z axes
- Micron-scale repeatability on all axes
- Smooth adjustable dual-range joystick control
- Backlit LCD display shows X, Y, and Z coordinates
- "Zero" and "Home" button for simple stand-alone operations
- Compact ergonomic tabletop control unit size is 9 cm x 23 cm x 16½ cm (3½" x 9" x 6½")
- Microprocessor control with RS-232 serial and USB communications
- Other functions including programmable positioning patterns and scans

Specifications

XY axis range of travel	380 mm x 380 mm (15" x 15")
XY axis resolution	< 3 μm
XY axis RMS repeatability (typical)	< 5 μm
XY axis maximum velocity	100 mm/sec
Z axis range of travel (typical)	100 mm (4")
Z axis resolution (encoder step)	22 nm
Z axis RMS repeatability (typical)	< 700 nm
Z axis maximum velocity	7 mm/sec

Large Stages

Automated XYZ Gantry Translation Stage

Lead Screw Options

Lead Screw Pitch Options	Rotary Encoder Resolution		Maximum Speed (Dynamic range = 400)	
	XY	Z	XY	Z
25.40 mm (Ultra-coarse)	N/A	88 nm	N/A	28 mm/sec
12.70 mm (Super-coarse)	1680 nm	44 nm	200 mm/sec	14 mm/sec
6.35 mm (Standard)	840 nm	22 nm	100 mm/sec	7 mm/sec
1.59 mm (Fine)	210 nm	5.5 nm	25 mm/sec	1.75 mm/sec

*Shown with standard 6.35 mm pitch lead screws

Part Numbers

GTS-1000: Gantry Translation Stage with 10" x 10" travel with LS-50 Z. Better than 3 μm resolution in XY; 100 mm/sec maximum speed better than 0.1 μm resolution in Z; 7 mm/sec maximum speed

The GTS-1000 stage requires a controller, below:

MS3: Three-Axis DC Servo Motor XYZ Controller

MS4: Four-Axis DC Servo Motor XYZ and Zoom Controller

GTS-1500: Gantry Translation Stage with 15" x 15" travel with LS-50 Z. Better than 3 μm resolution in XY; 100 mm/sec maximum speed better than 0.1 μm resolution in Z; 7 mm/sec maximum speed

The GTS-1500 stage requires a controller, below:

MS3: Three-Axis DC Servo Motor XYZ Controller

MS4: Four-Axis DC Servo Motor XYZ and Zoom Controller

LE-GTS-OPT: Linear Encoder Option for XY Axes



Linear Stages

LS-Series Linear Stages

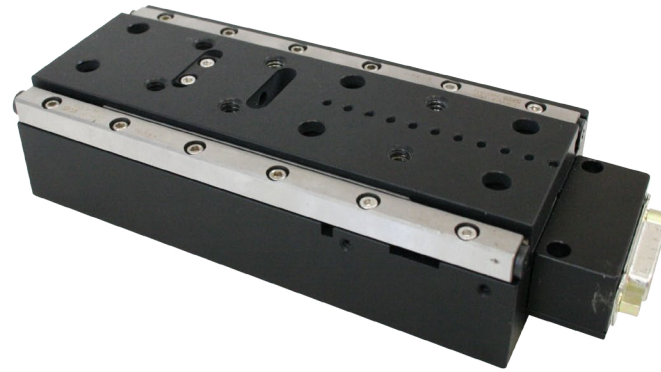

LS linear stages provide sub-micron accuracy, deriving their precise control by using closed-loop DC servomotors and employing high-resolution rotary encoders for positioning feedback. An optional linear encoder can be added to the unit to provide even greater positioning accuracy.

The stages utilize crossed-roller slides, precision lead-screws, and zero-backlash miniature geared DC servomotors for smooth and accurate motion. The units offer precise travel from 50 mm to 300 mm (2" to 12"). They can be used singly or stacked, vertically or horizontally, and can carry loads up to 4.5 Kg (10 lbs).

The units have built-in limit switches, and can be configured with a number of lead screw options as outlined in this section. In standard rotary encoder configuration and using ASI's MS-2000 control electronics, resolutions in the 50 nm to 100 nm range can be easily obtained. Repeatability factors of less than 300 nm RMS are also obtainable.

An optional linear encoder provides a scale resolution of 10 nm, and with a scale accuracy of $\pm 3 \mu\text{m}$ per length of scale. The MS-2000 controller provides automatic backlash correction, accepts industry standard commands, and accepts RS-232 or USB communication from a host computer.

Lead Screw Options

Lead Screw Pitch Options	Rotary Encoder Resolution	Maximum Speed
25.40 mm (Ultra-coarse)	88 nm	28 mm/sec
12.70 mm (Super-coarse)	44 nm	14 mm/sec
6.35mm (Standard)	22 nm	7 mm/sec
1.59 mm (Fine)	5.5 nm	1.75 mm/sec
0.653 mm (Extra-Fine)	2.2 nm	0.7 mm/sec

**Shown with rotary encoder and 6.35 mm pitch lead screw*

Part Numbers

LS-50-M: LS-50 Linear Stage, with sub-micron accuracy and 50 mm of travel (Metric).

LS-50-E: LS-50 Linear Stage, with sub-micron accuracy and 50 mm of travel (English).

LS-100-E: LS-100 Linear Stage, with sub-micron accuracy and 100 mm of travel.

LS-150-E: LS-150 Linear Stage, with sub-micron accuracy and 150 mm of travel.

LS-200-E: LS-200 Linear Stage, with sub-micron accuracy and 200 mm of travel.

LS-300-E: LS-300 Linear Stage, with sub-micron accuracy and 300 mm of travel.

LS-400: LS-400 Linear Stage, with sub-micron accuracy and 400 mm of travel.

The above Linear Stages require a controller:

MS1: Single-Axis DC Servomotor controller.

MS-1208: Bracket Mount. Typically two (2) used.

MS-1209: Slider.

Linear Stages

LS-Series Linear Stages

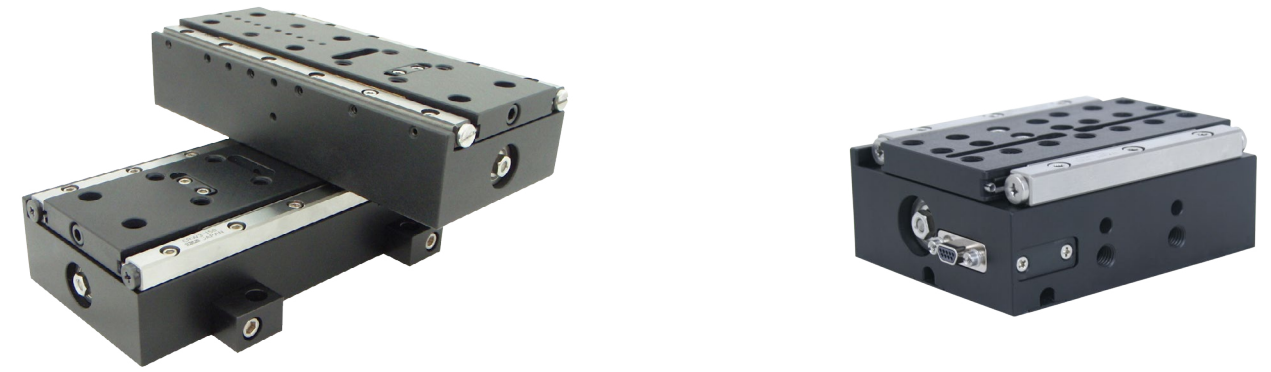

Specifications

Specifications	LS-25	LS-50	LS-100	LS-200	LS-400
Encoder Resolution*	22 nm	22 nm	22 nm	22 nm	22nm (.84 $\mu\text{m}\dagger$)
With Linear Encoder	10 nm	10 nm	10 nm	10 nm	10 nm
RMS repeatability (Typical)*	< 0.7 μm	< 0.7 μm	< 0.7 μm	< 0.7 μm	< 0.7 μm (< 8.0 $\mu\text{m}\dagger$)
With Linear Encoder (Typical)	200 nm	200 nm	200 nm	200 nm	200 nm
Leadscrew Accuracy	0.25 $\mu\text{m}/\text{mm}$	0.25 $\mu\text{m}/\text{mm}$	0.25 $\mu\text{m}/\text{mm}$	0.25 $\mu\text{m}/\text{mm}$	0.25 $\mu\text{m}/\text{mm}$
With Linear Encoder	$\pm 3 \mu\text{m}/\text{length scale}$	$\pm 3 \mu\text{m}/\text{length scale}$	$\pm 3 \mu\text{m}/\text{length scale}$	$\pm 3 \mu\text{m}/\text{length scale}$	$\pm 3 \mu\text{m}/\text{length scale}$
Maximum velocity*	7 mm/sec	7 mm/sec	7 mm/sec	7 mm/sec	7 mm/sec
Range of Travel	25 mm (1")	50 mm (2")	100 mm (4")	200 mm (8")	400 mm (16")
Length	86 mm (3.4")	152.5 mm (6")	203.5 mm (8")	305 mm (12")	594.5 mm (23.4")
With Connector**	137 mm (5.4")	233 mm (9.2")	286 mm (11.3")	369 mm (14.5")	675 mm (26.6")
With RA Connector**	--	195 mm (7.6")	247 mm (9.7")	380 mm (15")	363 mm (25")
Width	68.5 mm (2.7")	68.5 mm (2.7")	68.5 mm (2.7")	68.5 mm (2.7")	150 mm (5.9")
With Connector**	120 mm (4.7")	132.5 mm (5.2")	132.5 mm (5.2")	132.5 mm (5.2")	215 mm (8.5")
With RA Connector**	--	93.5 mm (3.7")	93.5 mm (3.7")	93.5 mm (3.7")	175 mm (6.9")
Height	35 mm (1.4")	30 mm (1.2")	30 mm (1.2")	30 mm (1.2")	50 mm (2")
Weight	.5 kg (1 lb)	1.4 kg (3 lbs)	1.9 kg (4 lbs)	2.4 kg (6 lbs)	9 kg (20 lbs)

** With 6.35mm pitch (4 TPI) Leadscrew*

*** May vary per available plug dimensions*

† with high-speed motor/gearhead configuration

Manual Stages

MIC-2500 Manual Stage



The MIC-2500 Manual Stage is a specifically designed, precise, stable platform for piezo scanning stages and comes standard with manual micrometers. The MIC-2500's standard configurations flat top plate allows for mounting XYZ piezo stages, manual manipulators, and uses ASI's K size inserts.

**Nikon TE2000 shown. Olympus IX81-71 also available.*

Specifications

XY axis range of travel	25 mm
Graduation	0.001mm
Accuracy	+/- 0.003 mm
Max Load	5 kg
Preload	10 N
Typical drifts in XY	1.15 μ m per 10° F change 0.210 per 1° C change

**Optional MA-12 Motorized Actuator (See Actuator Specifications)*

Rotary and Translation Stages

PRS-1000 Precision Rotary Stage

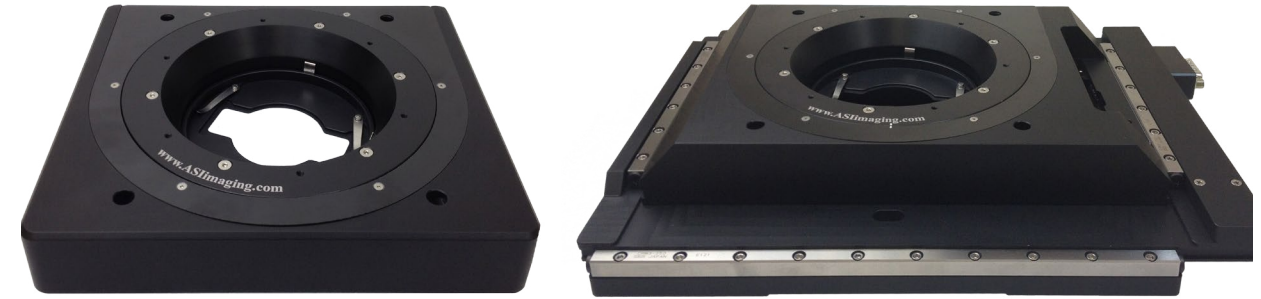

The PRS-1000 Precision Rotary Stage utilizes ASI's proven precise control through the use of closed-loop DC servomotors and angle encoded out drive. The low profile design with the ability to be integrated into our MS-2000 XY stages offers flexible usage. Standard versions have a \varnothing 95 mm clear through aperture, use all of ASI's C size inserts, and have M3 tapped holes on 125 mm D.B.C. The PRS-1000 is also available with solid top plates for vacuum applications and M6 on 25mm centers.

Specifications for Standard Configuration

Travel Range	360° Continuous (bi-directional)
Max Velocity	10°/s
Load Capacity	2kg (higher loads available)
Angle Encoder Resolution	0.00019°
Overall Height	30 mm
Clear Aperture	\varnothing 95 mm
Run Out	<20 μ m

Rotary and Translation Stages

FTP-2000 Focusing Translation Platform



The FTP-2000 Focusing Translation Platform has been specifically designed to provide a high resolution, and highly repeatable, means of controlling the X, Y and Z position of the stage. The unit is ideal for use with fixed stage microscopes, or any application where ultra precise XYZ positioning is required. All axes derive their precise control through the use of closed-loop DC servomotors employing high-resolution rotary encoders for positioning feedback. By using closed-loop control of the stage position, there is no chance that the stage will become lost, as can occur with open-loop micro-stepped stages after a number of moves and direction changes. The FTP-2000 stage utilizes crossed-roller slides, a high-precision lead screw, and zero-backlash miniature geared DC servomotors for smooth and accurate motion. The microprocessor-controlled MS-2000 control unit provides for RS-232 and USB communication with a host computer.

FTP-2000 Options

- Piezo Top Plates with Z ranges of 150 nm, 300, nm and 500 nm
- X, Y, and Z-axis Linear Encoders for high-accuracy positioning and focus control
- Larger stage top plate for attachment of micromanipulators, microinjectors, etc.
- Stage Wings for even more room for attachments
- Autofocus for stages with ASI Z-axis drives (requires NTSC, PAL, or S-Video analog signal)
- Other lead screw pitches are available

Features

- Closed-loop DC servo control of the X, Y, and Z-axes for precise positioning and highly repeatable focusing
- Wide dynamic speed range with XY joystick control
- Utilizes ASI's proven LS series linear positioners for Z axis control
- Z-axis clutch for easy switching between manual and motor-driven focus control
- Backlit LCD display shows X, Y, and Z coordinates
- "Zero" and "Home" button for simple stand-alone operations
- Compact ergonomic tabletop control unit size is 6" D x 9" W x 3" H (9 cm x 23 cm x 6½ cm)
- Microprocessor control with RS-232 serial and USB communications
- Proven operation with many popular software packages

Rotary and Translation Stages

FTP-2000 Focusing Translation Platform

Specifications for Standard Configuration

XY axis range of travel	120 mm x 75 mm
XY axis resolution (encoder step)	22 nm
XY axis RMS repeatability	< 700 nm
XY axis maximum velocity	7 mm /sec
Z axis resolution (encoder step)	50 nm
Z axis repeatability	± 50 nm
Z axis maximum velocity	1.6 mm /sec
Max Recommended Load (*higher loads available upon request)	5kg
Z axis travel	100 mm (50 mm option available)

*Shown with 6.35 mm pitch Lead Screw

Linear Encoder Options

Axis	Resolution	Scale Accuracy
XY	10 nm	± 3 µm per length of scale
Z (12 mm and 25 mm stroke)	50 nm	0.025 µm per mm

Lead Screw Options

Lead Screw Pitch Options	Rotary Encoder Resolution	Maximum Speed
25.40 mm (Ultra-coarse)	88 nm	28 mm/sec
12.70 mm (Super-coarse)	44 nm	14 mm/sec
6.35 mm (Standard)	22 nm	7 mm/sec
1.59 mm (Fine)	5.5 nm	1.75 mm/sec
0.635 mm (Extra-fine)	2.2 nm	0.7 mm/sec



Upright Stages

MS-2000 Low Mass Stage

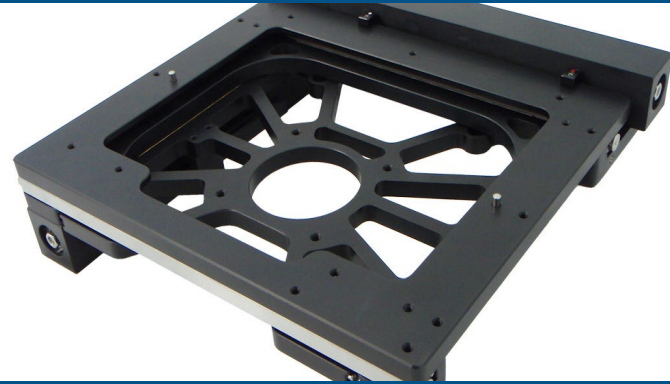

The MS-2000 Low Mass XY stage has been specifically designed to reach thermal equilibrium faster with 3/4 the mass of a regular stage while retaining ASI's legendary precision. The stage retains the high resolution, and high repeatability, of all ASI microscope stages. All axes derive their precise control through the use of closed-loop DC servomotors employing high-resolution rotary encoders for positioning feedback. By using closed-loop control of the stage position, there is no chance that the stage will become lost, as can occur with open-loop micro-stepped stages after a number of moves and direction changes. The MS-2000 XY stage utilizes crossed-roller slides, high-precision lead screws, and zero-backlash miniature geared DC servomotors for smooth and accurate motion. The microprocessor-controlled MS-2000 control unit provides for RS-232 and USB communication with a host computer.

Features

- Three-fourths the mass of a regular ASI stage
- Closed-loop DC servo control of the X and Y axes for precise positioning
- Wide dynamic speed range with XY joystick control
- Works with ASI's proven Z-axis drives
- Backlit LCD display shows the coordinates
- "Zero" and "Home" button for simple stand-alone operations
- Compact ergonomic tabletop control unit size is 6"D x 9"W x 3"H
- Microprocessor control with RS-232 serial and USB communications
- Proven operation with many popular software packages
- Suitable for stand-alone, OEM, and specialty applications

Specifications for Standard Configuration

XY axis range of travel	100 mm x 100 mm
XY axis resolution (rotary encoder step)	0.022 μ m
XY axis RMS repeatability	< 0.7 μ m
XY axis maximum velocity	7 mm/sec

Lead Screw Options

Lead Screw Pitch Options	Rotary Encoder Resolution	Maximum Speed
12.70 mm (Super-coarse)	44 nm	14 mm/sec
6.35 mm (Standard)	22 nm	7 mm/sec
1.59 mm (Fine)	5.5 nm	1.75 mm/sec
0.635 mm (Extra-fine)	2.2 nm	0.7 mm/sec

Linear Encoder Options

Axis	Resolution	Scale Accuracy
XY	10 nm	\pm 3 μ m per length of scale

Upright Stages

MS-2000 Small Stage



The MS-2000 XY stage has been specifically designed to provide a high resolution, and highly repeatable, means of controlling the X and Y position of a microscope stage. All axes derive their precise control through the use of closed-loop DC servomotors employing high-resolution rotary encoders for positioning feedback. By using closed-loop control of the stage position, there is no chance that the stage will become lost, as can occur with open-loop micro-stepped stages after a number of moves and direction changes. The MS-2000 XY stage utilizes crossed-roller slides, a high-precision lead screw, and zero-backlash miniature geared DC servomotors for smooth and accurate motion. The microprocessor-controlled MS-2000 control unit provides for RS-232 and USB communication with a host computer.

Features

- Closed-loop DC servo control of the XY-axes for precise positioning and repeatability
- Wide dynamic speed range with XY joystick control
- Backlit LCD display shows the coordinates
- Works with ASI's proven Z-axis drives
- Proven operation with many popular software packages
- "Zero" and "Home" button for simple stand-alone operations
- Microprocessor control with RS-232 serial and USB communications
- Compact ergonomic tabletop control unit size is 6"D x 9"W x 3"H (16½ x 23 x 9 cm)
- Suitable for smaller upright microscopes, stand-alone, OEM, and specialty applications

Product Compatibility

- Leica
- Nikon
- Olympus
- Zeiss

Specifications for Standard Configuration

XY axis range of travel	100 mm x 100 mm
XY axis resolution (rotary encoder step)	0.022 μ m
XY axis RMS repeatability	< 0.7 μ m
XY axis maximum velocity	7 mm/sec

Weight	5 lbs (2.27 Kgs)
Dimensions	8"D x 9"W x 2.5"H (20½ x 23 x 6.5 cm)

Lead Screw Options

Lead Screw Pitch Options*	Rotary Encoder Resolution	Maximum Speed
12.70 mm (Super-coarse)	44 nm	14 mm/sec
6.35 mm (Standard)	22 nm	7 mm/sec
1.59 mm (Fine)	5.5 nm	1.75 mm/sec
0.635 mm (Extra-fine)	2.2 nm	0.7 mm/sec

Linear Encoder Options

Axis	Resolution	Scale Accuracy
XY	10 nm	\pm 3 μ m per length of scale

*Standard Lead Screw Accuracy is 0.25 μ m per mm.

Upright Stages

OE-1250 Stable OEM System



ASI has designed the OE-1250 GEN II Stage specifically for manufacturers to be configurable and easily integrated into their systems. The OE-1250 Stage has custom mounting options, flat top designed with multiple configurations, higher load capacity, precise motion, and high repeatability. The OE-1250 provides controlled linear motion alignment, orthogonal movement, and lower driving friction. The stage retains the high resolution, and high repeatability, of all ASI microscope stages. All axes derive their precise control through the use of closed-loop DC servomotors employing high-resolution rotary encoders for positioning feedback. By using closed-loop control of the stage position, there is no chance that the stage will become lost, as can occur with open-loop micro-stepped stages after a number of moves and direction changes. The OE-1250 XY stage utilizes crossed-roller slides, high-precision lead screws, and zero-backlash miniature geared DC servomotors for smooth and accurate motion. The microprocessor-controlled OE-1250 control unit provides for RS-232 and USB communication with a host computer.

Features

- Closed-loop DC servo control of the X and Y axes for precise positioning
- Wide dynamic speed range with XY joystick control
- Works with ASI's proven Z-axis drives
- Backlit LCD display shows the coordinates
- "Zero" and "Home" button for simple stand-alone operations
- Compact ergonomic tabletop control unit size is 6"D x 9"W x 3"H
- Microprocessor control with RS-232 serial and USB communications
- Proven operation with many popular software packages
- Suitable for stand-alone, OEM, and specialty applications
- Custom mounting options
- Flat top design
- Multiple top plate configuration
- Higher load capacity
- Limbered limits (adjustable dove tail design)
- Higher orthogonal motion
- Controlled linear motion alignment
- Lower friction

Upright Stages

OE-1250 Stable OEM System

Specifications for Standard Configuration

XY axis range of travel	125 mm x 125 mm
XY axis resolution (rotary encoder step)	0.022 μ m
XY axis RMS repeatability	< 0.7 μ m
XY axis maximum velocity	7 mm/sec

Lead Screw Options

Lead Screw Pitch Options	Rotary Encoder Resolution	Maximum Speed
12.70 mm (Super-coarse)	44 nm	14 mm/sec
6.35 mm (Standard)	22 nm	7 mm/sec
1.59 mm (Fine)	5.5 nm	1.75 mm/sec
0.635 mm (Extra-fine)	2.2 nm	0.7 mm/sec

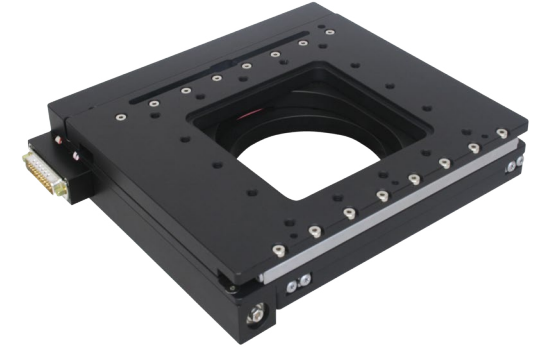

Upright Stages

MS-4400 XY Automated Stage



The MS-4400 XYZ provides a high resolution and highly repeatable means of controlling the X, Y, and Z position of the microscope stage. The MS-4400 XY stage has been specifically designed for larger upright microscopes like the Leica DMR-series, the Nikon Eclipse 80i, the Olympus BX series, and the Zeiss Axioplan, Axioskop 2, and Axio Imager. All axes derive their precise control through the use of closed-loop DC servomotors employing high-resolution rotary encoders for positioning feedback. By using closed-loop control of the stage position, there is no chance that the stage will become lost, as can occur with open-loop micro-stepped stages after a number of moves and direction changes. The MS-4400 XY stage utilizes crossed-roller slides, a high-precision lead screw, and zero-backlash miniature geared DC servomotors for smooth and accurate motion. The Z-axis drive also uses ASI's proven line of closed-loop motor drives, each custom fitted to the microscope. The microprocessor-controlled MS-2000 control unit provides for RS 232 and USB communication with a host computer.

Options

- X, Y, and Z-axis Linear Encoders for high-accuracy positioning and focus control
- Stage Inserts to hold a variety of slides, dishes, sealed glass chambers, multiwell microplates, perfusers, heaters, and many other special items
- Autofocus for stages with ASI Z-axis drives (requires NTSC, PAL, or S-Video analog signal)
- Other lead screw pitches are available
- Zeiss – AxioLab, AxioPhot II, Axioskop FS, AxioStar, Standard 16, Universal

Features

- Closed-loop DC servo control of the X, Y, and Z-axes for precise positioning and highly repeatable focusing
- Wide dynamic speed range with XY joystick control
- Utilizes ASI's proven Z-axis drives
- Z-axis clutch for easy switching between manual and motor-driven focus control
- Backlit LCD display shows X, Y, and Z coordinates
- "Zero" and "Home" button for simple stand-alone operations
- Compact ergonomic tabletop control unit size is 6" D x 9" W x 3" H
- Microprocessor control with RS-232 serial and USB communications
- Proven operation with many popular software packages

Product Compatibility

- Leica
- Nikon
- Olympus
- Zeiss

Upright Stages

MS-9500 XY Automated Stage



The MS-9500 XY motorized stage system has a travel range of 9" by 4" (225 mm x 125 mm) and has been specifically designed to scan eight 25 mm x 75 mm slides at a time while providing a high resolution, and highly repeatable, means of controlling the X and Y position of the microscope stage. All axes derive their precise control through the use of closed-loop DC servomotors employing high-resolution rotary encoders for positioning feedback. Optional linear encoders improve repeatability to less than 300 nm (typical) compared to the standard 700 nm rms rating, and improve resolution to 50 nm. By using closed-loop control of the stage position, there is no chance that the stage will become lost, as can occur with open-loop micro-stepped stages after a number of moves and direction changes. The microprocessor-controlled MS-2000 Control Unit provides for RS-232 and USB communication with a host computer.

MS-9500 Options

- X and Y-axis Linear Encoders for high-accuracy positioning, incorporated into the stage plates
- Auto Focus for stages with ASI Z-axis drives (requires composite video signal)
- Other lead screw pitches are available

Features

- Closed-loop DC servo control of the X and Y-axes for precise positioning and highly repeatable focusing
- Wide dynamic speed range with XY joystick control
- Can be used with ASI's proven Z-axis drives
- Backlit LCD display shows X and Y coordinates
- "Zero" and "Home" button for simple stand-alone operations
- Compact ergonomic tabletop control unit size is 6"D x 9"W x 3"H (9 x 23 1/2 cm)
- Microprocessor control with RS-232 serial and USB communications
- Proven operation with many popular software packages
- Suitable for stand-alone, OEM, and specialty applications as well

Specifications for Standard Configuration

XY axis range of travel	225 mm x 125 mm (9" x 4")
XY axis resolution	100 nm (typical)
XY axis RMS repeatability	< 700 nm (typical)
XY axis maximum velocity	7 mm/sec

Lead Screw Options

Lead Screw Pitch Options	Rotary Encoder Resolution	Maximum Speed
25.40 mm (Ultra-coarse)	352 nm	28 mm/sec
12.70 mm (Super-coarse)	176 nm	14 mm/sec
6.35 mm (Standard)	88 nm	7 mm/sec

Linear Encoder Options

Axis	Scale Resolution	Scale Accuracy
XY	20 nm	0.5 µm per 10 mm 1.5 µm per 100 mm

Part Number

MS-9500: XY Stage 225 mm x 125 mm of travel for scanning a quantity of eight 1" x 3" slides. Stage is closed loop with rotary encoders.

Contact ASI for assistance to discuss stage configuration

Z-Drives

SZ-2000 Stereoscopic Zoom Microscope



Based on ASI's proven DC servo motor technology, the SZ-2000 automates stereo zoom microscopes. The unit can be configured for motorized focus only, motorized focus with automated zoom control, or motorized focus with automated zoom control and an automated XY translation stage. The Z axis focus resolution varies slightly depending upon the model of the microscope, with 0.8 microns being the smallest step size available on a Nikon SMZ800. An optional pair of footswitches permits hands-free operation of any axis featuring an increment mode, with continuous motion after the switch has been held down for 1.5 seconds. The increment step size per footswitch tap is selectable as well as the continuous mode speed. The footswitch option offers operators a convenient and ergonomic means of controlling the microscope for routine tasks such as embryo transplanting.

Ultra precise DC servo motors and high resolution rotary encoders are used on all axes for smooth, error free operation. The Z-axis drive and automated zoom control are very easy to install and uses existing mount holes on the microscope so no modification of the microscope is necessary.

Since the ASI drive shaft clamps directly onto the microscope's fine focus shaft, the positioning is extremely accurate. A switch located on the control console operates a clutch that disengages the Z-drive motor drive from the fine focus shaft when the drive is not needed. When disengaged the microscope can be focused manually from both sides with the microscope's fine focus knobs. The position is continuously displayed and is still available for interrogation by computer. This feature lets the researcher note specific focus positions, or allows a computer to memorize them for later use in driving the Z-axis.

Precision gearing provides smooth control of the zoom function, and a precision DC servomotor with a built-in rotary encoder keeps track of positioning for error free operation.

Features

- Closed-loop DC servo control of all axes for precise positioning and highly repeatable focus and zoom
- Compact ergonomic tabletop control unit size is 6" D x 9" W x 3" H (9 cm x 23 cm x 16½ cm)
- Backlit LCD display shows coordinates
- Microprocessor control with RS-232 serial and USB communications
- Z-axis clutch for easy switching between manual and motor-driven focus control
- "Zero" and "Home" button for simple stand-alone operations

Z-Drives

SZ-2000 Stereoscopic Zoom Microscope

Specifications

Z axis resolution (encoder step)	0.8 µm
Z axis maximum velocity	12 mm/sec
XY axis range of travel*	100 mm x 100 mm
XY axis resolution (encoder step)*	0.088 µm
XY axis RMS repeatability*	< 0.7 µm
XY axis maximum velocity*	7 mm/sec

Product Compatibility

- Nikon
- Olympus

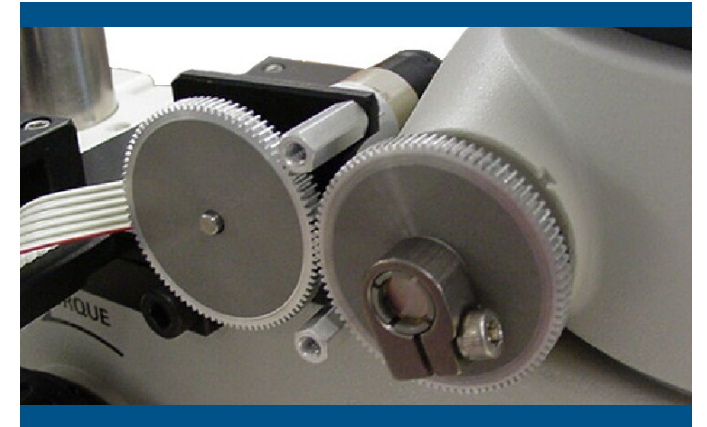

Focus, Tracking, and Stabilization

CRISP Autofocus System



ASI's Continuous Reflective Interface Sample Placement (CRISP) system is designed to maintain focus over time, i.e. compensate for thermal and other factors that may cause the sample to drift out of focus over time. It also can be used to maintain a given focal point while scanning the sample in XY. If you are looking to find the optimal focal point while scanning through the sample in Z please see our Video Autofocus system(pg.93).

Installation

CRISP is usually installed with an ASI Dual C-Mount Splitter (DCMS) that contains the required dichroic beam combiner and blocking filters and provides the C-Mount port for the camera.

CRISP Features

- Mounts onto any microscope's standard C-Mount port
- Maintains ideal focus for days
- Works with most normal microscope objectives
- Low noise electronics allows locking to glass/water interfaces
- Integrates with ASI Piezo-Z or motorized focus stages
- Simple post-lock fine adjustment of focus
- Automated control

Adjustments, Options, and Control

- Built-in C-Mount extension for optical offsets
- LED beam iris to match illumination beam to objective pupil for optimum performance
- Lateral detector adjustment
- Other LED colors possible
- LED intensity control
- Programmable gain and averaging functions to optimize system for stability or speed

Theory of Operation

The CRISP system projects the image of a mask illuminated with an IR LED into the sample plane. Only one half of the objective pupil is illuminated. This means that the point spread function of the objective is highly skewed, so that the reflected image of the mask will move laterally as focus is changed. CRISP detects this lateral motion of the LED image to obtain a focus error that is used to close the focus positioning loop.

Part Numbers

See "DCMS Options for CRISP" on next page (89).

Focus, Tracking, and Stabilization

CRISP Autofocus System

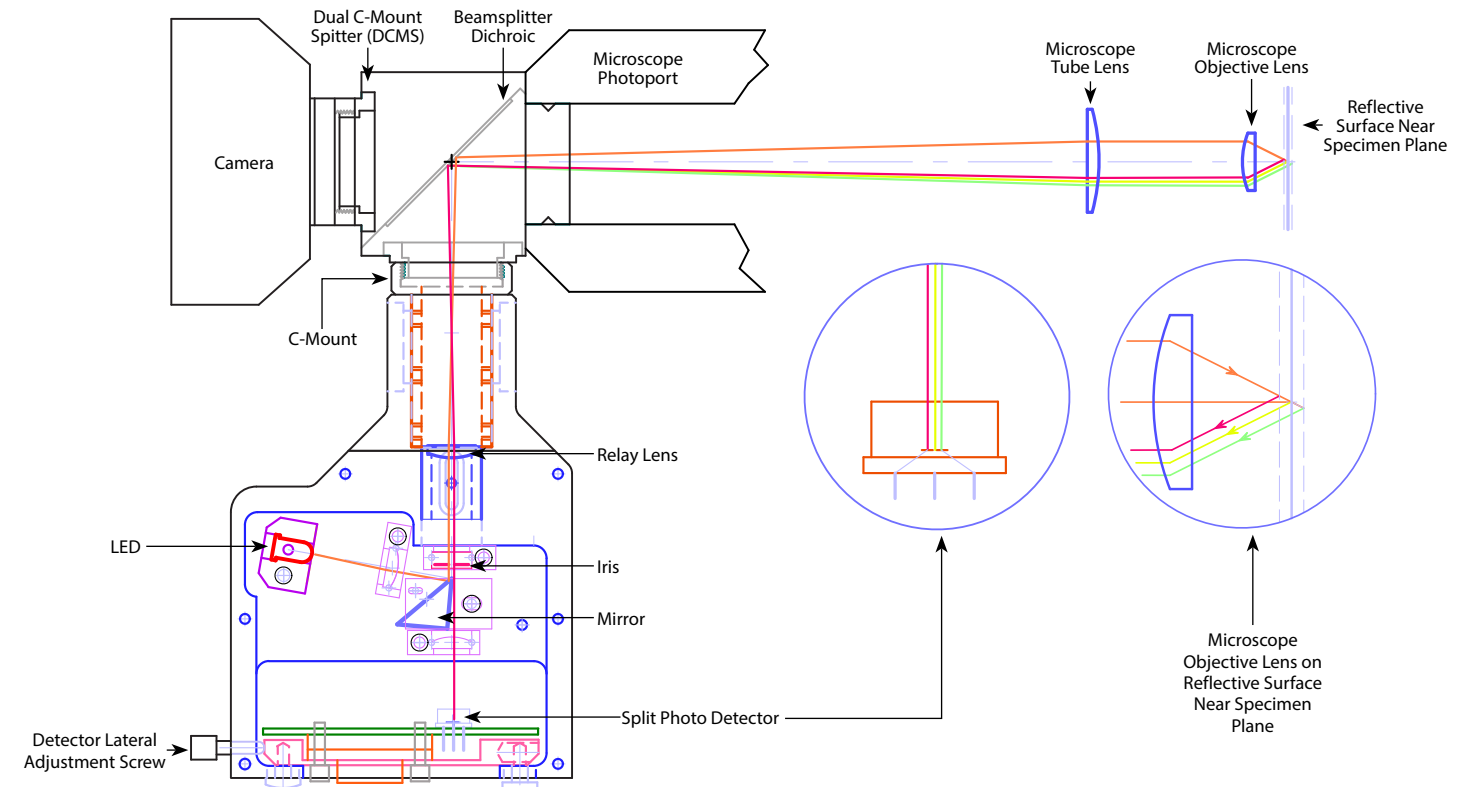

Specifications

Light Source	LED
Wavelength	Choose from 625 nm - 1050 nm
Optical Interface	C-Mount
Typical Focus Accuracy	<5% of Objective Depth of Focus
Controller	MS-2000 w/ CRISP card TG-1000 w/ CRISP card

Focus, Tracking, and Stabilization

Dual C-Mount Splitter - DCMS



The Dual C-Mount Splitter (DCMS) provides two parfocal C-Mount ports when mounted on many common microscopes. Typical uses include combining a fast analog autofocus camera system simultaneously with a high-resolution digital camera. The assembly accepts standard size mirrored and dichroic glass plates. Additionally, a standard filter can be inserted behind each of the C-Mounts. The male C-Mounts can be rotated and locked at any orientation. Photoport adapters are available for most microscopes, as applicable.

DCMS Options for CRISP

- CRISP-625:** CRISP with 600 nm LED; 600 nm SP camera filter; 628/32 nm LED cleanup filter.
- CRISP-660:** CRISP with 660 nm LED; 600 nm SP camera filter; 650/50 nm LED cleanup filter.
- CRISP-700:** CRISP with 650 nm LED; 700 nm SP camera filter; 700/50 nm LED cleanup filter.
- CRISP-720:** CRISP with 720 nm LED; 700 nm SP camera filter; 700/50 nm LED cleanup filter.
- CRISP-735:** CRISP with 735 nm LED; 700 nm SP camera filter; 750/50 nm LED cleanup filter.
- CRISP-780:** CRISP with 780 nm LED; 750 nm SP camera filter; 800/50 nm LED cleanup filter.
- CRISP-830:** CRISP with 830 nm LED; 750 nm SP camera filter; 800/50 nm LED cleanup filter.
- CRISP-850:** CRISP with 850 nm LED; 800 nm SP camera filter; 800/50 nm LED cleanup filter.
- CRISP-870:** CRISP with 870 nm LED; 850 nm SP camera filter; 850/50 nm LED cleanup filter.
- CRISP-890:** CRISP with 890 nm LED; 850 nm SP camera filter; 900/50 nm LED cleanup filter.
- CRISP-940:** CRISP with 940 nm LED; 900 nm SP camera filter; 950/50 nm LED cleanup filter.
- CRISP-970:** CRISP with 970 nm LED; 900 nm SP camera filter; 950/50 nm LED cleanup filter.
- CRISP-1050:** CRISP with 1050 nm LED; 1000 nm SP camera filter; 1050/50 nm LED cleanup filter.

Specifications

	50/50
	30/70
Mirror Options	20/80
	10/90
	Standard Dichroic Choices
Mirror Plate Dimensions	36.0 x 25.5 x 1.1 mm (1.42" x 1.00" x 0.04")
Filter Dimensions	25 mm (1" Diameter) 3.7 mm (0.145") Thickness
Built-in Photoport Adapter	30 mm Zeiss (OD) 22 mm (0.867") (ID)
C-Mount Standard (Male)	1.00" (OD), 32 threads/inch 22.1 mm (0.87") (ID)
Cube Dimensions	45.8 x 45.6 x 41.0 mm (1.80" x 1.79" x 1.61")

Adapter Part Numbers

- DCMS:** Dual C-Mount Splitter
- DCMS-Nik:** Adapter for DCMS to attach unit to Nikon inverted microscopes.
- DCMS-Leica:** Adapter for DCMS to attach unit to Leica inverted microscopes.
- DCMS-Olympus:** Adapter for DCMS to attach unit to Olympus BX51/IX71/81 microscope.

Focus, Tracking, and Stabilization

PhotoTrack



ASI's PhotoTrack solves the problem of tracking a moving specimen. Combined with ASI's closed loop DC servo motor XY stages, PhotoTrack allows you to keep your free-moving samples in your field of view (FOV) no matter where they want to go. PhotoTrack uses a low-light-level rapid position sensing quadrant PMT sensor to monitor a bright reference spot on the target. It then commands the XY stage to maintain that spot in the center of a microscope's field-of-view.

Applications Include

- Cell behavior studies
- Static alignment to fluorescent fiducials
- Optical recording of neurons in moving animals
- Using high-power objectives to track labeled samples from organelles to organisms

Part Numbers

- Quad-PMT:** Quadrant PMT Detector. Quadrant photomultiplier tube in a custom designed light tight C-Mount housing. Unit includes control board that offers manual control of gain. Control board also contains over exposure protection and reset circuitry.
- DCMS:** Dual C-Mount Splitter

Specifications

Sensor Mount	Parfocal C-Mount
Sensor Controls	Manual Gain, On/Off, Iris, Overload Reset
Beam Splitter Ratio	20/80, 10/90, or Dichroic
PMT Type	Hamamatsu 4-channel XY quadrant
PMT Protection	High voltage shutdown on overload
PMT Usable Dynamic Range	> 60 dB
Servo Loop Time	3 milliseconds
Read Time	2 milliseconds
Overall Response Time	< 25 milliseconds
Sensor Dimensions (H x W x D, not counting plug)	74 mm x 94 mm x 79 mm 2.9" x 3.7" x 3.1"
Controller for PhotoTrack Sensor	Integrated with specially-configured ASI MS-2000 controllers

Focus, Tracking, and Stabilization

XYZ Tracker



About the XYZ Tracker

Imaging freely moving or semi-restrained model organisms like *C. elegans*, drosophila larvae, and larval zebra fish is useful for many studies. Example applications include behavioral genetics, linking neuronal activities with behaviors, and probing responsive to stimuli.

XYZ Tracker keeps a specimen in the field of view and in focus. It uses ASI's Tunable Lens and a secondary camera to gather images from different focal planes without moving the objective or sample. It then evaluates those images and automatically adjusts the XYZ axes. The XY and Z tracking can be enabled or disabled independently.

XYZ Tracker Features

- Tracks specimens like *C. elegans*, drosophila larvae, larval zebrafish, and other model organisms
- Continuous autofocus
- Bright-field and fluorescence imaging
- Multiple tracking algorithms available (OpenCV's Mean Shift, Optical flow and more)
- Micro-Manager based plug-in (Windows OS only)

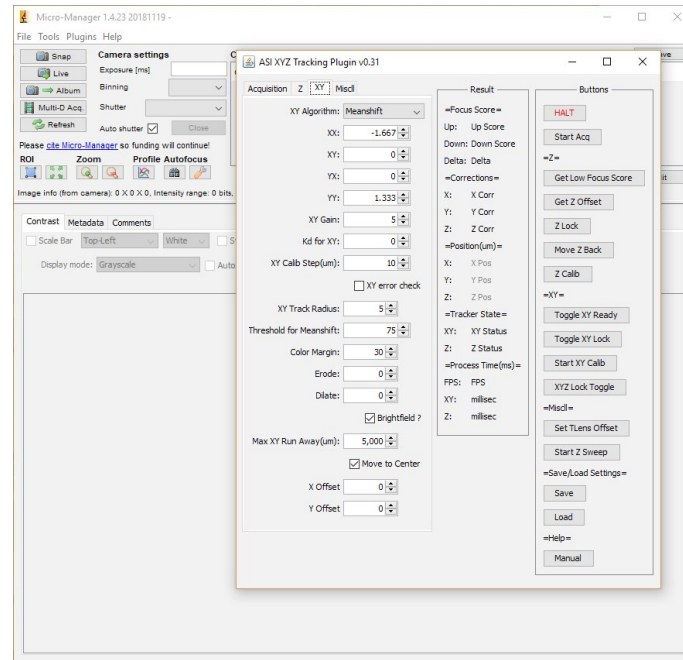

Focus, Tracking, and Stabilization

XYZ Tracker

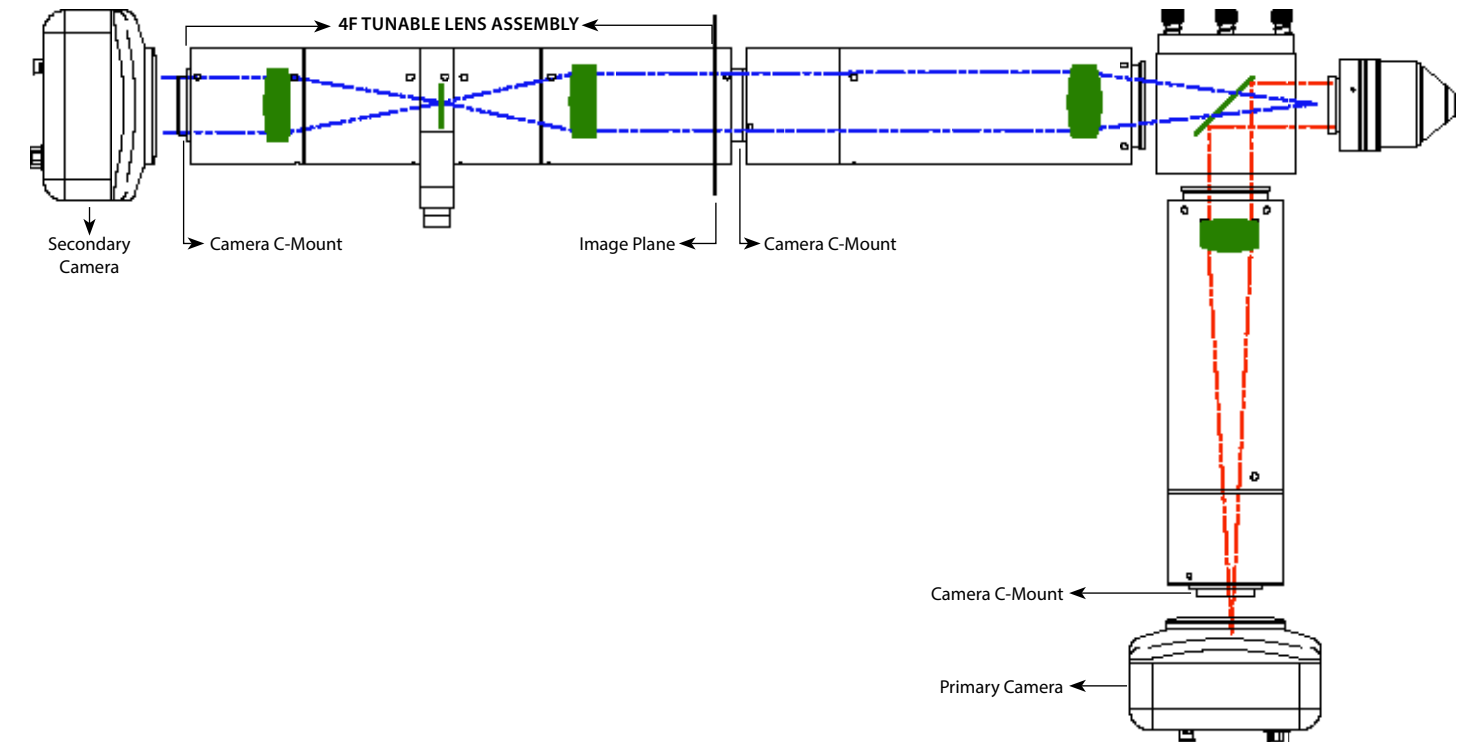

Elements

XYZ Tracker consists of a software plug-in, a Tunable Lens, ASI's XY and Z stages, and a secondary camera.

The Micro-manager plug-in is the heart of the XYZ Tracker system. Through it, the user can control the camera, tunable lens, and our XY and Z stages. Micro-Manager is a free and open source imaging solution with support for many cameras and microscopes.

ASI's Tunable Lens system uses C-mounts to connect to the imaging camera and to the microscope's photo port. The Tunable Lens is an important component of Z tracking, which is technically more difficult than XY tracking.

Part Numbers

- Tunable Lens Driver Card : TGTLG
- Tunable Assembly: C60-TUNELENS-4F

Focus, Tracking, and Stabilization

Video Autofocus System

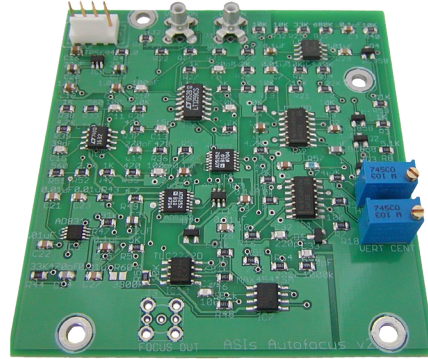

ASI's video autofocus provides a simple focus control solution when using an analog video camera and any of ASI's products with Focus Control, including standard and piezo XYZ stage systems, linear and gantry stage systems, and stand-alone MFC-2000 focus controllers.

The autofocus system uses the spatial information present in the analog video signal to determine a focus value. Firmware algorithms then maximize this focus value by adjusting the focal position with an ASI focus drive. The autofocus option requires a standard NTSC/RS170, PAL/CCIR, or S-Video analog video signal from a camera. Autofocus with a digital camera is possible with a dual-output camera, or by incorporating ASI's Photoport Beam Splitter.

ASI's autofocus system has improved sensitivity and stability, 8X higher resolution, and incorporates an auto-calibration routine that automatically accommodates for diverse lighting conditions, specimen characteristics, and different objective powers.

Video Auto Focus Features

- Fast Focusing – Typical accurate focus operation takes about one second, and can be configured for even faster operation.
- Accurate Focusing – Where there is a “best focus” plane, ASI's autofocus will find it as well as any human operator.
- Objective Lens Protection – Once zeroed, autofocus will not move more than 0.2 mm closer to the sample for safety.
- Focus Value Readout – The focus value is always displayed on the LCD readout so you can easily verify correct operation.
- Video Region Select – Rectangular subsection of the video frame may be selected as the active focus region. Selection is highlighted on monitor output.
- Auto Calibration – Performs a series of scans and selects various internal parameters to achieve optimal focusing.
- Focus Algorithms to fit your need – Autofocusing can be accomplished via push-button on the controller or with commands from the host computer.
- Normal Full Range and Hill Detect

Focus, Tracking, and Stabilization

Fast Piezo Objective Mover - f-POM



Features

- Specialty piezo objective mover provides high-speed, large load, long-travel operation
- Travel range of 150 µm, 300 µm, or 500 µm available
- Closed-loop control
- Ideal for custom microscope applications
- Standard MS-2000 Adept Controller or special high performance driver available for most rapid operation

Physical Dimensions

- 102 mm x 60 mm x 20 mm
- Thru aperture 18.0 mm
- Mounting holes: Four M4-0.7 on 19 mm x 47 mm pattern
- Objective threads M25 - 0.75 (other available)

ADEPT High-Performance Piezo Controller Specifications

Specification	f-POM- 150	f-POM- 300
Piezo Travel Range (+/- 5%)	150 µm	300 µm
Piezo smallest move resolution w/ 16 bit DAC	2.2 nm	4.5 nm
Maximum Load for full range travel	1.2Kg	600g
Transient Response time (10%-90%) for moves below 30% travel range	3.3 ms	
External Analog input (BNC)	0 to 10 Volts	
Closed Loop 3dB Bandwidth w/ 280gm load for moves 70% of travel range	75Hz	

ADEPT Standard Piezo Controller Specifications

Specification	f-POM- 150	f-POM- 300	f-POM- 500
Piezo Travel Range (+/- 5%)	150 µm	300 µm	500 µm
Piezo smallest move resolution w/ 16 bit DAC	2.2 nm	4.5 nm	7.6 nm
Maximum Load for full range travel	1.2Kg	600g	500g
Transient Response time (10%-90%) for moves below 30% travel range	11 – 15 ms		
External Analog input (BNC)	0 to 10 Volts		
Closed Loop 3dB Bandwidth w/ 600gm load	30Hz		

Illumination Control

LED Lamp Illuminator and Drive



ASI's high intensity LED lamp source and driver is a simple way to provide transmitted light illumination, or even epi-fluorescent excitation when appropriate LED color is used. For transmitted light a white LED is used. LEDs are available in a range of colors with typically 20-30 nm spectral half-widths for fluorescent excitation. The LEDs are high powered and can supply ~100mW of luminous intensity depending on the specific wavelength. Using several beam splitter cubes and LED lamps, it is possible to construct a multi-color LED excitation system with these off-the-shelf parts.

Illumination Application For Epi-illumination

C60-LAMP-ADPT(Universal Lamp Adapter) allows the MIM-LED-LAMP to be placed on the image side of a C60-TUBE-xx lens assemblies to make it into a excitation light condensers that can generate a collimated light. The lamp adapter contains a field stop aperture.

For Trans-illumination

The MIM-LED-LAMP can be used with OLY-TRANS-ILLUM kit for transmitted light inverted applications.

The OLY-TRANS-ILLUM kit is based upon the Olympus IX2-LWUCD condenser which combines a long working distance (WD 27mm) and a high numerical aperture (NA 0.55).

The trans-illumination kit contains the IX2-LWUCD with its 5-position turret and adjustable iris diaphragm. The kit also has a centerable condenser mount, a rack and pinion z-positioner for condenser focusing, and a high brightness LED lamp illuminator with adjustable field iris.

An optional kit (OLY-DIC-OPTION) of Olympus DIC prism and polarizer components is available for high-contrast, high-resolution images with 20X and 40X objectives.

For additional information on DIC microscopy see:

www.olympusmicro.com/primer/techniques/dic/dicconfiguration.html
www.olympusmicro.com/primer/techniques/dic/dicconfiguration.html

For Fluorescence Excitation

For fluorescence microscopy where multiple wavelengths of excitation are needed, several C60-SHORTPORT; can be used to connect Multiple MIM-LED-LAMPS (each with a LED of specified wavelength).

The C60-SHORTPORT has a provision for a Dichroic filter to be installed so as to redirect light sources to the same port.

This assembly can then be connected to a C60-TUBE-xx with a C60-LAMP-ADPT to generate a collimated light source.

LED Drivers

The MIM-LED-LAMPS can be ordered with one of two kinds

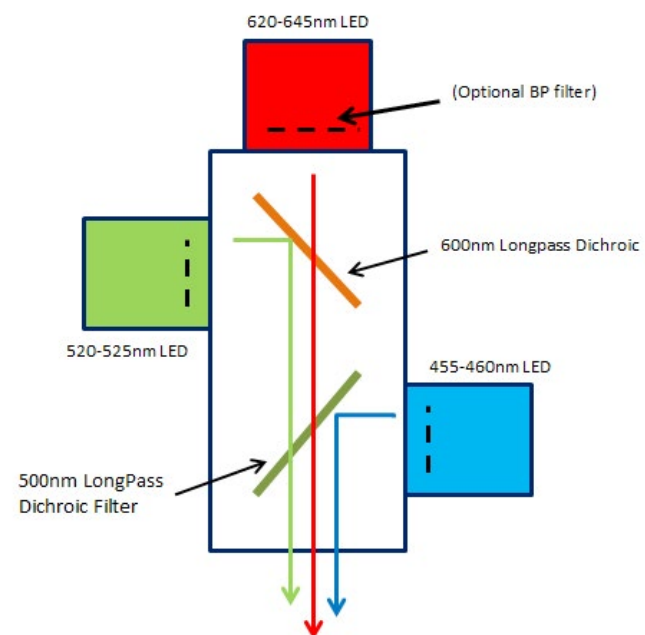

Illumination Control

LED Lamp Illuminator and Drive

Differences between MIM-LED-LAMP and MIM-LED-LAMP-NR

MIM-LED-LAMP	MIM-LED-LAMP-NR
It has an onboard LED Driver. It can be used stand-alone or with our controller.	It does not come with an onboard LED Driver, and it will required TGLED card to drive it.
The one available TTL Out on our controller and Tiger plug-in cards is used to generate a PWM to control the brightness of the illuminator.	TGLED has a dedicated PWM driver which frees up TTL out ports.
TTL Out will not be available for other uses, and adding another MIM-LED-LAMP isn't possible.	A TGLED card can drive up to four (4) MIM-LED-LAMP-NRs.
The TTL Out port produces a PWN frequency around 1 KHz; low frequency can cause small camera flicker.	PWM frequency is as high as 97 KHz; this prevents the camera from flicking.

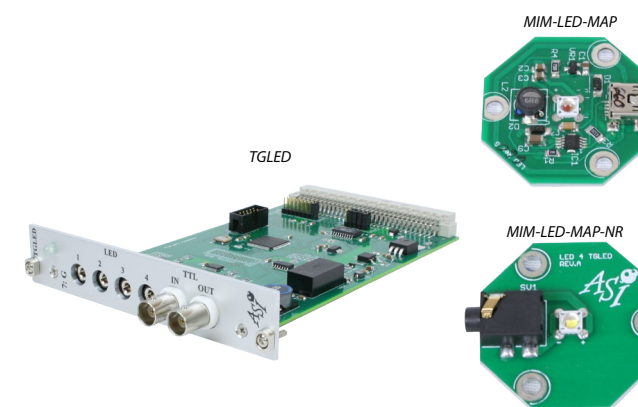

LED Wavelengths Available

- Listed below are the available wavelength options for the MIM-LED-LAMP.365
- 385
- 405
- 455
- 480
- 490
- 505
- 525
- 560
- 590
- 625
- 630
- 635
- 640
- 660
- 740
- 850
- 940
- Cool White

Example Setup

- The setup to the right is made of the following components:
- Three MIM-LED-LAMPS-NR , with 455nm , 523nm and 640nm LEDs
- Two C60-SHORTPORT
- Two C60-RA 2nd Port Dichroic Sliders 1mm , with 600nm and 500nm Longpass Dichroic
- Two Zeiss to Ring Adapter , and
- One C60-IRIS

The Zeiss to Ring Adapter have provision for 25mm Bandpass filters.

Illumination Control

FW-1000 High Speed Filter Wheel



ASI's FW-1000 filter wheel utilizes a closed-loop DC servo motor to provide high speed (less than 40 milliseconds between adjacent positions) and low vibration operation (less than 3×10^{-4} kg-m²/s maximum vibration torque impulse). The unit employs a high-resolution rotary encoder for positional feedback and utilizes non-volatile flash memory to store programmable filter sequences and delays. Motion can be triggered by TTL input pulse, and the controller will output a TTL sync pulse upon arrival at the commanded filter position. The closed loop design allows for precise control of speed and velocity profiles. Wheels are available to hold sixteen 25 mm, eight 25 mm, six 32 mm filters or four 40 mm filters. Multiple filter wheels can be controlled from a single controller. Adapters are available to attach the system to the excitation or emission ports of any research grade microscope. The FW-1000 unit can be easily configured for OEM applications.

Features

- Low vibration operation
- Fast switching (<40 ms between adjacent filter positions)
- Simple TTL Interface
- RS-232 programmable filter sequence
- Operates with stand alone controller FW-1000-SA, or on our Tiger controller with a filter wheel card
- Each controller module can operate two filter wheels
- Excitation and emission adapters are available for nearly all research-grade microscopes

Options

- 8-Position Filter Wheel Disk for 25 mm diameter filters (standard)
- 6-Position Filter Wheel Disk for 32 mm diameter filters
- 16-Position Filter Wheel Disk for 25 mm diameter filters

Illumination Control

FW-1000 High Speed Filter Wheel

Specifications

Minimum Switching Time	< 40 ms	
Maximum Vibration Torque Impulse	< 3×10^{-4} kg.m ² /s	
Dimensions	Filter wheel	203 mm x 118 mm x 29 mm
	Controller	58 mm H x 142 mm W x 194 mm L
Electrical	Voltage	110-240 VAC, 50-60 Hz
	Power	160 Watts

Part Numbers

- FW-1000-6:** 6-position (32 mm) filter wheel with controller
- FW-1000-8:** 8-position (25 mm) filter wheel with controller
- FW-1000-16:** 16-position (25 mm) filter wheel with controller
- FW-1002-6:** Two 6-position (32 mm) filter wheel with controller
- FW-1002-8:** Two 8-position (25 mm) filter wheel with controller
- FW-0002-6:** Two 6-position (32 mm) filter wheel with (no controller)
- FW-0002-8:** Two 8-position (25 mm) filter wheel with controller (no controller)
- FW-SC-NO:** Normally-Open Shutter for filter wheel
- FW-SC-NC:** Normally-Closed Shutter for filter wheel



Photomultipliers and Detectors

PMT-200 Photomultiplier



Various mounting configurations available including female C-Mount a flat flange mount with two 3 mm bolt holes 32 mm apart.

Features

- High sensitivity
- Manual or externally-programmable PMT gain
- Automatic overexposure shutdown
- Wide dynamic range
- Easy to use
- Works with the TG-1000 controller
- Supports two PMT tubes
- Manual control as well as PC control thru
- RS-232 serial communication

Specifications

Sensor (Standard)	Hamamatsu H5784-03, H10722, H10723
Bandwidth	DC to 20kHz
Spectral Response	185 to 920 nm
Sensitivity (at 420 nm)	150 V/nW to 260V/nW
Output	0 to 4 V

Control voltage +0.8 V (In the output signal, there is a shot noise associated with the signal.)

H10722 Series Characteristics (at +25° C)

Parameter	-110, -113	-210	-01, -04	-20	Unit
Radiant Sensitivity	220	260	150	150	V/W
Peak Sensitivity Wavelength	400	400	400	400	
Settling Time			10		
Effective Area			ø8		s
Ripple Noise (peak to peak)			0.5		mm
Frequency Bandwidth (-3dB)			DC to 20 kHz		V/A

Part Numbers

PMT-ASI-200: Photomultiplier Tube in a Custom-designed light-tight C-Mount housing. Housing includes special optical collection element to maximize photon collection onto PMT sensor.

TG8: Eight-slot power supply and chassis/box for motion control cards. Bench size 9.25"W x 5.5"H x 10.25"D. 100-240 VAC Input.

TIGER CONTROLLER MODULE CARD

Photomultipliers and Detectors

PMT-200 Photomultiplier

Typical Spectral Response

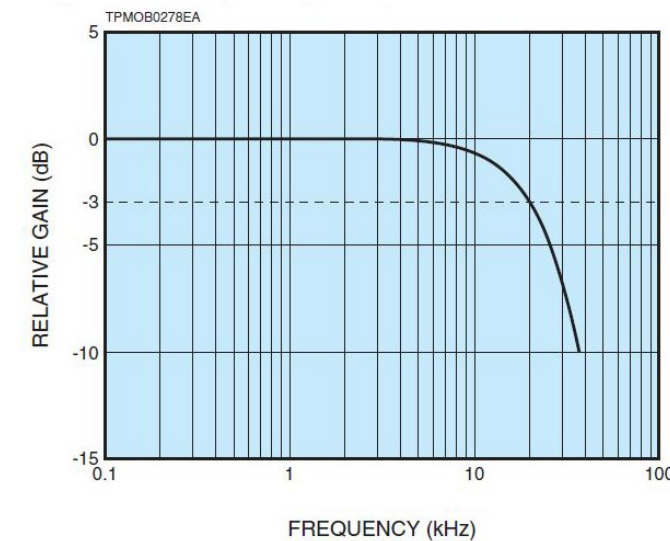
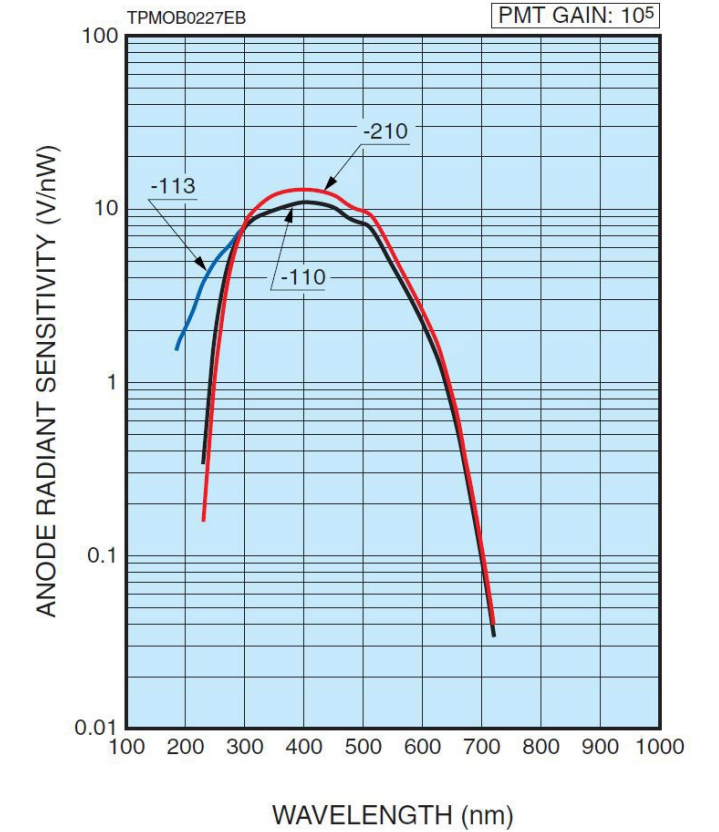
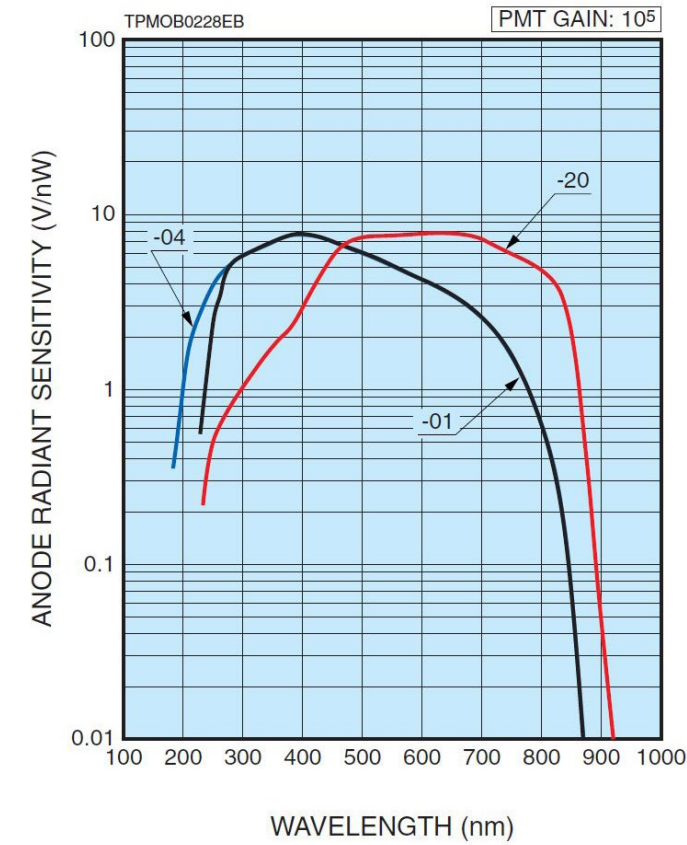

Photomultipliers and Detectors

PMT-200 Photomultiplier

Supported Photosensor Modules:

Type	Type Serie No.	Spectral Response 200 400 600 800(nm)	Frequency Response DC 100 200(kHz)	Photosensitive Area (mm)	Outside Size		Input Voltage (V)	Feedback Resistance Remarks
					Cubic Ratio	Dimensions (mm)		
Voltage Output	H10722	230 to 920	0 to 20	• $\varnothing 8$	1.3	22 x 22 x 60	+/-5	1 M Ω
	H10723	230 to 920	0 to 200	• $\varnothing 8$	1.4	51 x 24 x 25	+/-5	100 K Ω
	H9306	185 to 900	0 to 20	— 3.7 x 13	2.3	19 x 53 x 51	+/-15	1 M Ω
	H9307	185 to 900	0 to 200	— 3.7 x 13	2.3	19 x 53 x 51	+/-15	100 K Ω
	H11462	185 to 900	20 to 200	— 4 x 20	8.0	38 x 95 x 50	+/-5	1 M Ω (20k Hz) 100 K Ω (200 kHz)
	H7827	300 to 850	20 to 200	● $\varnothing 15$	3.2	26 x 50 x 56	+/-15	1 M Ω (20k Hz) 100 K Ω (200 kHz)
	H10492	300 to 850	20 to 200 to 8000	● $\varnothing 22$	5.1	$\varnothing 35$ x 120	+/-15	1 M Ω (20 kHz) 100 K Ω (200 kHz, 8 MHz)
	H10493	185 to 850	20 to 200 to 8000	● $\varnothing 25$	8.2	$\varnothing 35$ x 192	+/-15	1 M Ω (20 kHz) 100 K Ω (200 kHz, 8 MHz)

Manipulation and Injection

MPPI-3 Pressure Injector



The Milli-Pulse Pressure Injector, MPPI-3 produces gas pressure pulses to an injection pipette. The unit offers precise linear control of both pressure and pulse duration. Alternatively, an external source such as a signal generator can be used to control the pulse width and rate.

The MPPI-3 provides three methods to initiate the pressure pulse, in either Trigger or Gated mode:

- Front panel pushbuttons
- External TTL input signal
- Optional footswitch

Continuous output allows fine-tuning of the flow rate and clearing clogs from pipettes. Maximum input pressure is 100 psi (690 kPa). The output pressure is adjustable from 0 up to 100 psi. An internal gas filter increases for reliability and ease of maintenance.

The MPPI-3 has an input for an optional Back Pressure Unit (BPU). This option prevents any reverse flow in a pipette caused by capillary action after a pulse by providing an adjustable (0-to-15 psi or 0-to-100 kPa) back pressure.

The new MPPI-3 case allows stacking of multiple controllers. The compact size and low cost makes the MPPI-3 an ideal choice for your pressure injection needs.

Optional Accessories for the MPPI-3

- Back Pressure Unit (BPU)
- Micropipette Holder Kit
- Footswitch

Part Numbers

- MPPI-3:** Milli-Pulse Pressure Injector, with 6' each of 1/16" tubing and 1/8" tubing
- BPU:** Back Pressure Unit Option
- M-PIP-Kit:** Micropipette Holder Kit Option
- M-PIP:** Micropipette Holder Only
- FTSW:** Footswitch Option
- REP-FLT:** Replacement Filter
- M-10:** Magnetic Base Stand for Micromanipulators
- 00-49-903-6000:** Tilting Base

Manipulation and Injection

MPPI-3 Pressure Injector



Specifications

Input Pressure Range	100 psi (0 to 690 kPa)
Output Pressure Range	Regulated 0 to 100 psi (0 to 690 kPa) (Maximum output depends upon input pressure)
Output Pulse Range	Four user-settable ranges: 5 ms to 100 ms, 5 ms to 100 ms, 5 ms to 10 s, 5 ms to 60 s Minimum duration limited by the pneumatic solenoid valve to approximately 5 ms
Output Pulse Setting	Via front panel 10-turn calibrated dial
Output Pulse Accuracy	0.4% of full scale (crystal controlled)
Output Pulse Repeatability	0.4% of full scale (1% over the life of the valve)
Output Pressure Gauge	Front panel analog gauge: 0 to 100 psi (0 to 690 kPa)
Valve Life Expectancy	100 million cycles
Modes of Operation	Continuous flow, Timed Pulse Duration flow control, Gated flow control
Control Options	Front panel pushbutton switch, external TTL input signal, footswitch or other type of manual switch
Sync Out	Allows monitoring of the valve control and the daisy-chaining of multiple controllers, as well as synchronizing the injection pulse with micromanipulators and piezo cell penetrators
Gas Input and Back Pressure Fitting	1/8" (3.18 mm) Barbed hose fittings
Gas Output Fitting	1/16" (1.59 mm) Barbed hose fitting
Recommended Gas	Nitrogen or clean dry compressed air (Internally-mounted input gas filter provided)
Power Requirements	Power Module: 100 to 240 VAC, 50 to 60 Hz, 0.5 A (Direct Power Connection: 12 VDC, 1.5 A, 18 W)
Size	2.7" H x 8.2" W x 8.5" D (69 mm x 209 mm x 216 mm)
Weight	2.4 lb (1100 g)

Manipulation and Injection

Märzhäuser Micromanipulators

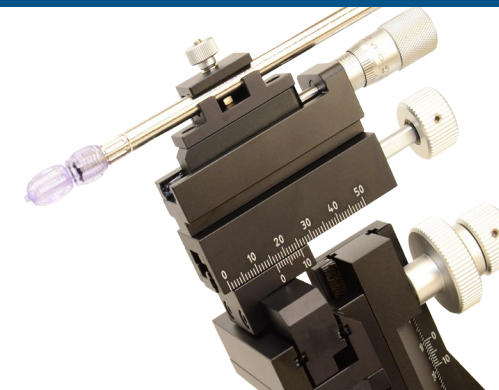

Märzhäuser Micromanipulators

ASI offers Märzhäuser's line of micromanipulators and piezo devices. The micromanipulators are built to demanding specifications and are a standard within the scientific community. The piezo devices are used for piercing cell walls quickly and precisely. We offer both manual and motorized micromanipulators with a wide range of features and configurations. We can special order manipulators, such as the MD4, MMJ, and PZ10 micromanipulators from Märzhäuser which we do not keep in stock.

MM33

The popular MM33 Micromanipulator (pictured above left) is a small and compact unit for manual manipulation in all three axes. The scales on the slides allow readings of the coarse adjustment with an accuracy of 0.1 mm. The additional x-axis fine control is achieved with a micrometer screw with a resolution of 10 µm. The range of travel is 37 mm in the x-axis, 20 mm in the y-axis, and 25 mm in the z-axis. The fine control has a travel of 10 mm. The micromanipulator is supplied with either a 10 mm or a 12 mm clamp for attachment. An 80° tilting base is offered as an option.

The MM33 is commonly used with ASI's MPPI-3 Milli-Pulse Pressure Injector for injecting a wide range of cells including oocytes, zebrafish, and other embryos.

Part Numbers:

- 00-42-101-0000:** MM33 Right w/ 10 mm or 12 mm clamp.
- 00-42-102-0000:** MM33 Left w/ 10 mm or 12 mm clamp.
- 00-42-103-0000:** MM33 Right w/ tilting base.
- 00-42-104-0000:** MM33 Left w/ tilting Base.

DC-3K

The DC3-K Micromanipulator (pictured above right) is equipped with manual as well as motorized drives in all 3 axes. Since this micromanipulator does not have to be operated by hand, but rather through the motor controls, it provides a smooth vibration-free positioning of injection tools or electrodes even under highest magnifications and when working with structures smaller than one micron. The manual adjustment capabilities of this manipulator are the same as the MM33, and can be read from scales to a resolution of 0.1 mm. The motorized motion of the three fine adjustment slides are driven by means of precision micrometer screws with 10 µm readout resolutions and DC motors. With the MS-314 Control Unit, resolution is approximately 500 nm.

The DC-3KS version has the additional capability of a swing-in / swing-out x-axis platform. This allows for the rapid and easy exchange and cleaning of tools without losing time for readjustment.

Part Numbers:

- 00-42-105-0000:** DC3K Right
- 00-42-106-0000:** DC3K Left
- 00-42-107-0000:** DC3K Right, w/ swing-out/swing-in option
- 00-42-104-0000:** DC3K Left, w/ swing-out/swing-in option

(All four require either an MS314, STM3, or PM10 Controller for operation.)

Manipulation and Injection

MX130 4-Axis Micromanipulator



The MX130 Manipulator is designed to maximize available space. The narrow profile design allows multiple manipulators to be placed in one quadrant. The MX130 provides 38 mm coarse and 5mm fine positioning travel in the X axis. Two and a half turns of the coarse adjustment knob will fully retract the device. One complete turn of the large fine position knob results in 300 μm of travel. Since the MX130 utilizes precision lead screws and machining, the travel is smooth and precise, and allows sub-micron positioning. The assembly is equipped with a probe clamp for easy changing of electrodes, pipettes, or other implements.

Y and Z axis adjustments are accomplished with the fine adjustment screws mounted on the back of the device. Additionally, the Z axis adjust screw can be configured with its knob on the top or the bottom, which ever provides the best access. The device angle is easily set by loosening the locking screw. The slotted mounting base provides for rough rotational positioning and flexible mounting options, either base or post. Left-hand or right-hand models allow flexibility to suit the application.

The extra length dovetail stage of the X axis, combined with the spring-loaded pivot mechanism (patent #6590723) of the other two axes, allow for a high level of stability. This allows for smooth and precise micromanipulation.

Manipulation and Injection

MX130 4-Axis Micromanipulator

Features

- Repeating probe holder
- Combined coarse and fine control on X-axis.
- Narrow, space-saving design.

Part Number

MX-130: 4-axis Manual Micromanipulator. Low profile, narrow space-saving design. Available as left- or right-handed. Maximum X-axis travel of 43 mm, with 5 μm resolution.

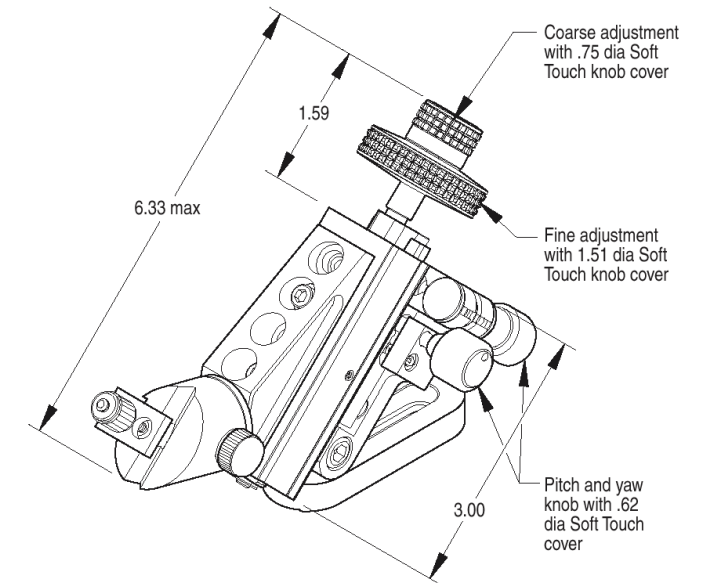

Manipulation and Injection

MA-12 Motorized Actuator



The ASI MA-12 motorized actuators offer high resolution in a lightweight, compact package, and have been designed to replace manual micrometers that have 1/4"-80 threads. The MA-12-B is for use with 3/8" barrel clamps. The units come complete with built in limit switches to provide overdrive protection and home positioning. Current limiting within the ASI control electronics also provides additional overdrive protection. The built in encoder provides 512 counts per revolution, giving a theoretical minimum resolution of 30 nm, and when used with the ASI controller provides bidirectional repeatability of better than +/- 0.75 μ m.

Applications include the automation of TIRF injectors as shown in the images below, as well as automation of manual translation stages that utilize manual micrometers.

Features

- Compact servo actuator
- Submicron resolution
- 3 mm/s maximum velocity
- Replacement for most 12 mm or 1/2" manual actuators
- Compatible with 1/4"-80 Thread or 3/8" Barrel-Fitted stages and mounts
- Built-in limit switches
- Current limiting with ASI controller

Part Number

MA-12: Motorized Actuator

Specifications

Bidirectional Repeatability	1.5 μ m
Backlash	<8 μ m
Maximum Acceleration	4 mm/sec ²
Maximum Velocity	3 mm/sec
Velocity Stability	\pm 0.125 mm/sec
Maximum Vertical Load Capacity	4.5 kg
Maximum Horizontal Load Capacity	9 kg
Recommended Horizontal Load Capacity	<7.5 kg
Recommended Vertical Load Capacity	<4.0 kg
Minimum Achievable Incremental Movement	0.05 μ m
Minimum Repeatable Incremental Movement	0.2 μ m
Maximum Percentage Accuracy	0.82%
Homing Repeatability	\pm 1.0 μ m
Operating Temperature Range	-20 to 65 °C
Max Motor Coil Temperature	85 °C
Limit Switch Life Time	>100,000 Cycles
Weight	0.134 kg
Travel Range	12.0 mm

Manipulation and Injection

Stage Wings

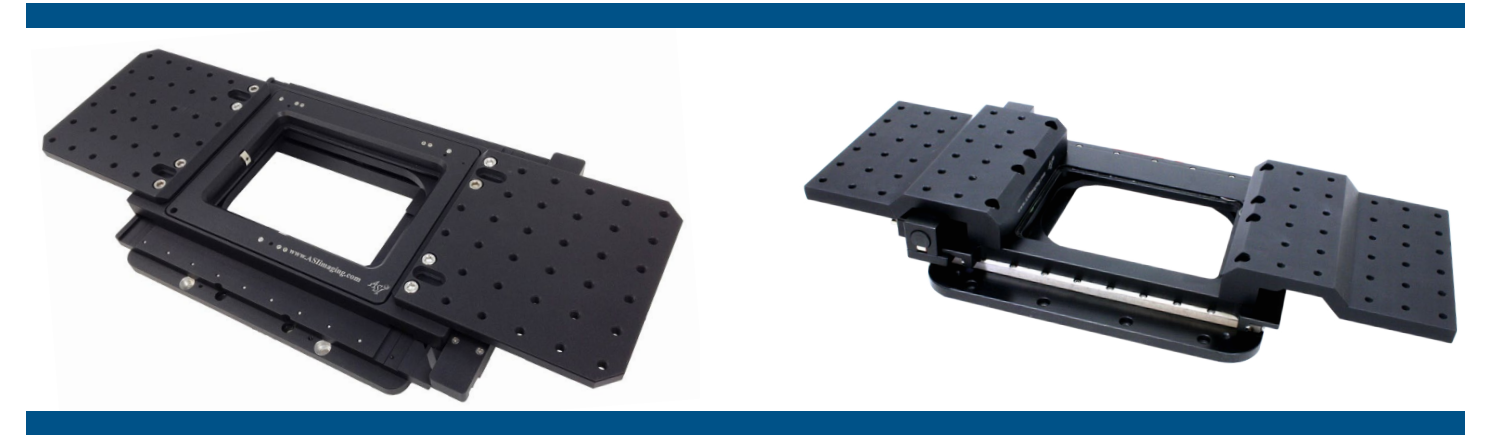

The ASI stage wing option consists of two solidly machined extender wings that can be securely bolted onto ASI's precision automated stages. The stage wing option allows micromanipulators, like the MM-33 unit shown here, to be easily and securely attached to the top plate of the stage. This allows the micromanipulator to be moved in both the X and Y axis with the sample. The stage wing option also allows other devices such as perfusion tubes or Stereotaxic equipment to be securely attached to the stage. The standard wings have 1/4 - 20 threaded holes on one-inch centers.

Metric versions are available with M6 x 1 threaded holes on 25 mm centers.

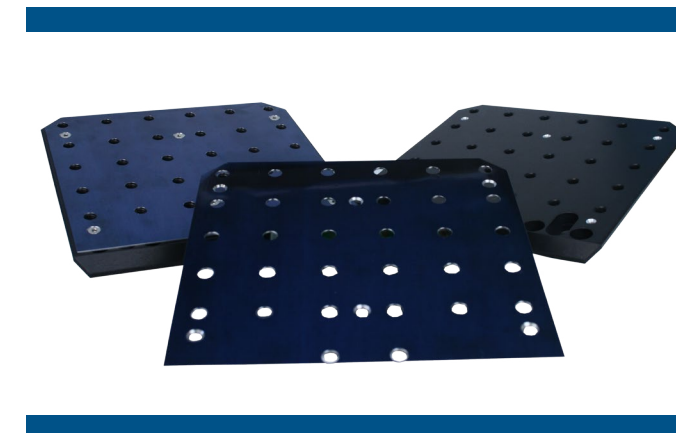

Part Numbers

STWS (Standard): Stage Wings-English. For MS-2000 inverted microscope stages only. Pair (2) of standard wings with 1/4 - 20 threaded holes on 1 in. centers.

STWM (Metric): Metric Thread Stage Wing Option for Inverted microscope stages only. Pair (2) of standard wings with 6mm threads on 25mm centers

FTSWM: Stage Wings for flat top stage. Metric M6 threads on 25 mm centers. Pair (2).

FTSWM-MAG: Stage Wings Magnic addaptors for flat top stage. Blue tempered spring steel plate used with STWS stage wings for magnetic mounts while keeping the mass low.

Stage Inserts

160 x 110 mm Flat Plate Inserts

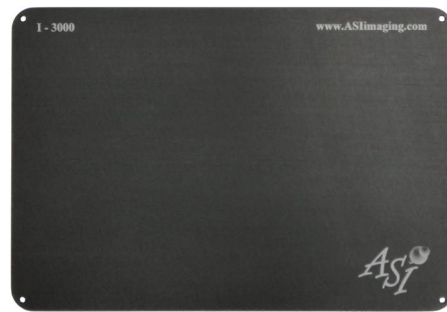

Solid Plate Insert (I-3000)

The I-3000 solid top insert provides a solid base plate that can be modified by the user to meet their particular application needs.
Depth from top of Insert: N/A
Overall Thickness: 8.0 mm

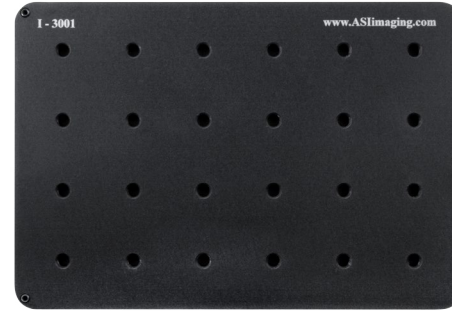

Metric Plate Insert (I-3001) English Plate Insert (I-3002)

The I-3001/2 Metric/English breadboard insert provides a removable base plate for mounting equipment using either M5 bolts on 25 mm centers or 1/4"-20 bolts on 1-inch centers.
Depth from top of Insert: N/A
Overall Thickness: 8.0 mm



Glass Plate Insert (I-3008)

The I-3008 glass insert provides a large specimen area the full size of the insert. It is made out of borofloat polished glass.
Depth from top of Insert: N/A
Overall Thickness: 3.1 mm

Stage Inserts

160 x 110 mm Petri Dish and Flask Inserts



Universal Petri Dish Insert (I-3026)

The I-3026 insert accepts 30 mm to 65 mm (1.18" to 2.56") Petri dishes. The unit places the bottom of a dish about 7.4 mm below the top of the insert.
Depth from top of Insert: 7.4 mm
Overall Thickness: 8.0 mm



35 mm and 50 mm Wilco Dish Insert (I-3034)

The I-3034 insert accepts WillCo dishes with a maximum bottom outside diameters of 33.9 mm (1.33") and 50.0 mm (1.97"). The unit places the bottom of the dishes about 7.3 mm below the top of the insert. Surrounding cavity diameters are 37.7 mm (1.48") and 54.0 mm (2.12") to accommodate the dish covers. Hole diameters are 31.3 mm (1.23") and 47.5 mm (1.97"). Ease of access side slots. Spring clips for secure stability.
Depth from top of Insert: 7.4 mm
Overall Thickness: 8.0 mm



35 mm and 39 mm Petri Dishes Inserts (I-3035 and I-3039)

The I-3035 and the I-3039 inserts accept Petri dishes with a maximum bottom outside diameter of 35.3 mm (1.39") and 39 mm (1.54") respectively. The units place the bottom of the dishes about 7.4 mm below the top of the inserts. The surrounding cavity diameters are 41.2 mm (1.62") and 46.6 mm (1.83") to accommodate a dish cover. Hole diameters are 31.8 mm (1.25") and 36.4 mm (1.43"). Ease of access side slots. Spring clips for secure stability.
Depth from top of Insert: 7.4 mm. It doesn't applied to the 39 mm Petri Dish Insert (I-3039)
Overall Thickness: 8.0 mm



50 mm and 60 mm Petri Dishes Inserts (I-3050 and I-3060)

The I-3050 and the I-3060 inserts accept Petri dishes with a maximum bottom outside diameter of 50.0 mm (1.97") and 61.9 mm (2.44") respectively. The units place the bottoms of the dishes about 7.4 mm below the top of the insert. The surrounding cavity diameters are 53.9 mm (2.12") and 67.0 mm (2.64") to accommodate a dish cover. Hole diameter are 47.5 mm (1.87") and 57.0 mm (2.25"). Ease of access side slots. Spring clips for secure stability.
Depth from top of Insert: 7.4 mm
Overall Thickness: 8.0 mm

Stage Inserts

160 x 110 mm Petri Dish and Flask Inserts



85 mm and 88 mm Petri Dishes Inserts (I-3085)

The I-3085 and the I-3088 insert accept Petri dishes with a maximum bottom outside diameter of 88.9 mm (3.50") and 90.9 mm (3.58") respectively. The units place the bottom of the dish about 7.4 mm below the top of the insert. Hole diameter is 82.5 mm (3.25") and 84.2 mm (3.31"). Ease of access side slots. Spring clips for secure stability. Depth from top of Insert: 7.4 mm Overall Thickness: 8 mm



Flask Insert for Corning T75 Flask (I-3092-C)

The I-3092-C insert accepts Corning T75 flasks. The unit places the bottom of the flask about 7.3 mm below the top of the insert, and uses a spring-loaded clamp for stability. The I-3092-C also holds SARSTEDT-brand T75 flasks. Depth from top of Insert: 7.3 mm Overall Thickness: 8.0 mm

Stage Inserts

160 x 110 mm Petri Dish and Flask Inserts



Insert for Nunc T75 Flask (I-3092-N)

The I-3092-N insert accepts Nunc T75 flasks. The unit places the bottom of the flask about 7.3 mm below the top of the insert, and uses a spring-loaded clamp for stability. Depth from top of Insert: 7.3 mm Overall Thickness: 8.0 mm



Flask Insert for Corning T75 Flask (I-3092-BD)

The I-3092 BD insert T75 BD Falcon flask. The unit places the bottom of the flask about 6mm below the top of the insert, and uses a spring-loaded clamp for stability. Depth from top of Insert: 6 mm Overall Thickness: 8.0 mm



98 mm Petri Dish Insert (I-3098)

The I-3098 insert accepts Petri dishes with a maximum bottom outside diameter of 100.8 mm (3.97"). The unit places the bottom of the dish about 7.4 mm below the top of the insert. Hole diameter is 94.5 mm (3.72"). Ease of access side slots. Spring clips for secure stability. Depth from top of Insert: 7.4 mm Overall Thickness: 8.0 mm



Flask Insert for Nunc T25 Flask (I-3090-N)

The I-3090-N insert accepts Nunc T25 flasks. The unit places the bottom of the flask about 7.3 mm below the top of the insert, and uses a spring-loaded clamp for stability. Depth from top of Insert: N/A Overall Thickness: 8 mm



Flask Insert for Corning T25 Flask (I-3090-C)

The I-3090-C insert accepts Corning T25 flasks. The unit places the bottom of the flask about 7.3 mm below the top of the insert, and uses a spring-loaded clamp for stability. Depth from top of Insert: 7.3 mm Overall Thickness: 8.0 mm

Stage Inserts

160 x 110 mm Sealed Glass Chamber Inserts



33 mm Three-Dish Insert (I-3033)

The I-3033 insert accepts any dish with a maximum bottom outside diameter of 33.0 mm (1.30"), and places them about 7.4 mm below the top of the insert. The I-3033 is designed to hold any combination of ASI's stainless steel I-3033-25D and I-3033-20D Sealed Coverslip Dishes (see below). These autoclavable dishes have replaceable 25 mm (0.98") or 20 mm (0.78") glass coverslip bottoms, sealed in place by O-rings. Spring clips for secure stability. Dishes do not come with insert.
 Depth from top of Insert: 7.4 mm
 Overall Thickness: 8.0 mm



Sealed Coverglass Rectangular Chamber (I-3078-2450)

Autoclavable stainless steel rectangular chamber with replaceable 50 mm x 24 mm coverglass bottom, sealed in place by an O-ring. Outside dimension is 76.0 mm x 50.5 mm (2.99" x 1.99"). Inside diameter at bottom (viewable window) is 42.7 mm x 16.7 mm (1.68" x 0.65"). Height is 10.7 mm (0.42").
 Depth from top of Insert: N/A
 Overall Thickness: N/A



Rectangular Chamber Insert (I-3078)

The I-3078 insert accepts a rectangular dish with a maximum bottom outside dimension of 76.2 mm x 50.8 mm (3.00" x 2.00"), and places it about 6.7 mm below the top of the insert. The I-3078 is designed to hold ASI's stainless steel I-3078-2450 (see below). This autoclavable dish holds a replaceable 50 mm x 24 mm (1.97" x 0.95") coverglass bottom, sealed in place by an O-ring. Ease of access side slots. Spring clips for secure stability. Dishes do not come with insert.
 Depth from top of Insert: 6.7 mm
 Overall Thickness: 8.0 mm



20 mm or 25 mm Sealed Coverslip Dish (I-3033-20D or I-3033 25D)

Dish inserts for I-3033. 20 or 25mm.
 Depth from top of Insert: N/A
 Overall Thickness: N/A

Stage Inserts

160 x 110 mm Silver Finger Inserts



Slide Insert with Finger

The I-4012 slide insert accepts most slides with a standard width of 75 mm (3"). The unit has a silver spring-loaded finger that holds the slide in place and is common to most standard microscope stages. The finger can easily be pulled back to install the slides which rest on surface of the insert and are recessed about 6.8 mm below the top of the insert. The I-4012 offers the advantage of versatility and ease of loading slides for screening large numbers of samples. Available as High-Rise (I-4013), Ultra-High-Rise (I-4015) and Flush Versions (I-4016).

Standard: I-4012

Depth from top of Insert: 6.8 mm
 Overall Thickness: 8.0 mm



High-Rise I-4013

Depth from Top of Insert: 3.8 mm
 Overall Thickness: 5.3 mm



Ultra High-Rise I-4015

Rise from top of Insert: 6.7 mm
 Overall Thickness: 9.5 mm

Flush Version I-4016

Depth from top of Insert: 0.0 mm
 Overall Thickness: 8.0 mm

Stage Inserts

Special Item Inserts

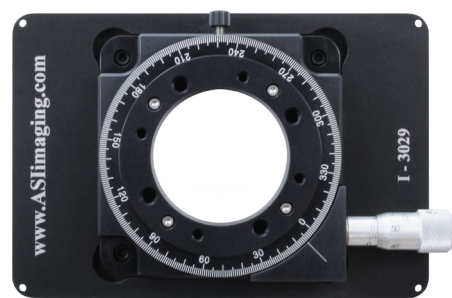

Manual Rotary Stage Insert (I-3029)

The I-3029 2-inch Aperture Manual Rotary Stage Insert allows full 360° coarse rotation by hand at 1° resolution as read from the graduated scale on the platform. Coarse adjustment may be locked, and fine adjustments performed over a 10° range with 1 arc-minute resolution and accuracy using the precision micrometer. Maximum wobble is 1 arc-minute. The stage has a central aperture of 50.8 mm. Custom sample holders can be machined into its top. Depth from top of Insert: 31 mm Overall Thickness: 34 mm



Siskiyou Perfusion Chamber Insert (I-3015)

The I-3015 insert provides a 75.0 mm by 50.0 mm (2.95" x 1.97") opening to hold a Siskiyou perfusion chamber. The unit is recessed to place the bottom of the chamber about 4.8 mm below the top of the insert. Depth from top of Insert: 4.8 mm Overall Thickness: 8 mm



LabTek™ Chambered Slide Insert (I-3016)

The I-3016 slide insert provides a 57.9 mm by 26.9 mm (2.28" x 1.06") opening to securely hold one 57x26 mm (2.25" x 1.0") LabTek™ chambered slide manufactured by Nalge Nunc. The unit is recessed to place the bottom of the slide about 7.5 mm below the insert top. Depth from top of Insert: 7.5 mm Overall Thickness: 8.0 mm



Bioptechs Stage Heater Insert (I-3017)

The I-3017 insert holds a Bioptechs FCS2 stage heater. The unit is recessed to place the bottom of the heater about 7.1 mm below the top of the insert. Depth from top of Insert: 7.1 mm Overall Thickness: 8.0 mm

Stage Inserts

Special Item Inserts



Multiwell Microplate Insert (I-3020)

The I-3020 and the I-3020L insert provide a 128.0 mm by 86.1 mm (5.04" x 3.39") opening that accepts any multiwell microplate with an SBS Standard 127.5 x 85 mm (5" x 3 1/3") footprint; for example, a 96-well microplate. The unit places the bottom of a wellplate about 7.4 mm below the top of the insert. Offer option with ledge. NOTE: The equivalent High-Rise version of this insert is the I-3028-B96 PARC High-Rise 96-Well Slide Insert. Depth from top of Insert: 7.4 mm Overall Thickness: 8.0 mm



LabTek™ Chambered Slide Insert (I-3016X3)

The I-3016 X 3 slide insert provides three 57.9 mm by 26.9 mm (2.28" x 1.06") opening to securely hold three 57 mm x 26 mm (2.25" x 1.0") LabTek™ chambered slide held by three spring loaded levers. The unit is recessed to place the bottom of the slides about 7.5 mm below the insert top. Depth from top of Insert: 7.5 mm Overall Thickness: 8.0 mm



Multiwell Microplate Insert with Solenoid Lock (I-3020-MLLAC)

This is a special version of the I-3020 with a solenoid locking mechanism for holding and releasing multiwell microplates, and special side cutouts to accommodate a robot's gripper. Depth from top of Insert: 7.4 mm Overall Thickness: 8.0 mm



Dagan Stage Heater Insert (I-3019)

The I-3019 insert provides a 99.0 mm by 97.0 mm (3.90" x 3.82") opening to hold a Dagan HE-100-series thermal stage. The unit is recessed to place the bottom of the heater about 7.0 mm below the top of the insert. Depth from top of Insert: 7.0 mm Overall Thickness: 8.0 mm

Stage Inserts

Special Item Inserts

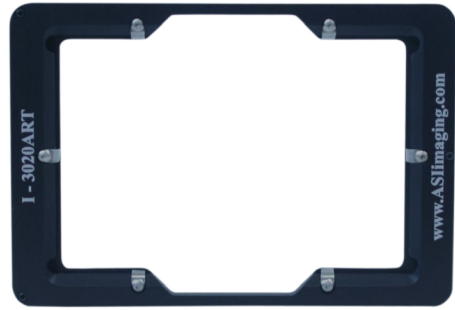

Multiwell Microplate Insert for Robotics (I-3020-ART)

This is a special version of the I-3020 with special cutouts on the sides to accommodate a robot's gripper for the automated insertion and removal of microplates.

Depth from top of Insert: 7.4 mm
Overall Thickness: 8.0 mm



PARC 3x5 Slide Insert (I-3021)

The I-3021 insert provides a 127.5 mm by 76.7 mm (5.02" x 3.02") opening to hold a PARC 3x5 slide. The unit is recessed to place the bottom of the slide about 7.2 mm below the top of the insert.

Depth from top of Insert: 7.2 mm
Overall Thickness: 8.0 mm

Stage Inserts

Special Item Inserts



Mouse-Holding Insert (I-3024)

The I-3024 insert provides a 128.0 mm by 86.1 mm (5.04" x 3.39") opening to hold a lowered platform for in vivo mouse imaging. (This is the same opening size that accepts an SBS Standard multiwell microplate.) There are two 21.0 mm (0.83") off-axis holes for viewing from below. The unit's recession places the bottom of the specimen about 8.5 mm below the top of the insert.

Depth from top of Insert: 8.5 mm
Overall Thickness: 9.5 mm



PARC High-Rise 3x5 Slide Insert (I-3028)

This is a special version of the I-3021 with a much shallower recession that places the bottom of the slide about 1.5 mm below the top of the insert. Available for upright microscopes that cannot move close enough to achieve correct focusing, although a condenser extender may be needed to obtain Kohler illumination.

Depth from top of Insert: 1.5 mm
Overall Thickness: 8.0 mm



Stage Insert 14mm Riser (I-3023)

The I-3023 is a 14.3 mm (0.56") extender ring commonly fitted to an ASI inverted stage to allow any of ASI's 160 mm x 110 mm slide inserts to be raised 14.3 mm, and allow Piezo objective holders to be easily used.

Depth from top of Insert: 7.4 mm
Overall Thickness: 8.0 mm



PARC High-Rise 96-Well Slide Insert (I-3028-B96)

The I-3028-B96 insert provides a 128.3 mm by 86.1 mm (5.05" x 3.39") opening to hold a PARC 96-well slide. (This is the same size opening that accepts an SBS Standard multiwell microplate.) The unit is recessed to place the bottom of the slide about 1.5 mm below the top of the insert.

NOTE: This insert is the equivalent of a High-Rise version of the I-3020.
Depth from top of Insert: 1.5 mm
Overall Thickness: 8.0 mm



Semiconductor Wafer Insert (I-3025)

The I-3025 insert provides a 100.1 mm (3.94") partially circular opening to hold a standard 100 mm semiconductor wafer. The unit is recessed to place the bottom of the wafer about 7.5 mm below the top of the insert.

Depth from top of Insert: 7.5 mm
Overall Thickness: 8.0 mm



Warner Stage Heater Insert (Series 20 and 30) (I-3018-20 or I-3018-30)

The I-3018-20 insert provides a 91.4 mm (3.60") diameter by 9.1 mm (0.35") deep opening to hold a Warner stage heater, plus offers 360 degree continuous rotation. This is for the Series 20 Warner Incubator. The I-3018-30 insert provides a 91.4 mm (3.60") diameter by 9.1 mm (0.35") deep opening to hold a Warner stage heater, plus offers 360 degree continuous rotation. This is for the Series 30 Warner Incubator.

Depth from top of Insert: 9.1 mm
Overall Thickness: 10.0 mm

Stage Inserts

160 x 110 mm Stage Inserts



Universal Insert (I-3091)

The I-3091 universal insert has two adjustable sliders to hold different sized slides, dishes up to 70 mm (2.75"), or a LabTek™ chambered slide. The bottoms of the slides or dishes are recessed about 7.3 mm below the top.

Depth from top of Insert: 7.3 mm
Overall Thickness: 8.0 mm



Single Slide Insert (I-3010)

The I-3010 slide insert accepts a single 25 mm x 75 mm (1" x 3") slide. The unit is recessed to place the bottom of a slide about 7.5 mm below the top of the insert.

Depth from top of Insert: 7.5 mm
Overall Thickness: 8 mm

Stage Inserts

160 x 110 mm Stage Inserts

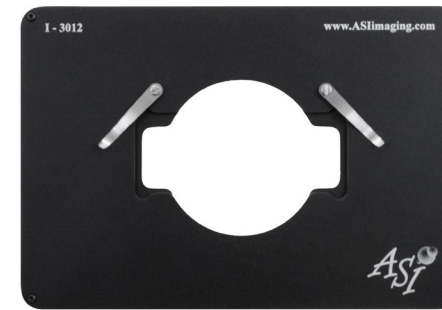

Single Slide Insert High-Rise Version (I-3012)

This is a special version of the I-3010 with a milled-out bottom to allow easy use of piezo objective holders. It is very slightly recessed to place the bottom of a slide about 1.7 mm below the top of the insert.

Depth from top of Insert: 1.7 mm
Overall Thickness: 8.0 mm

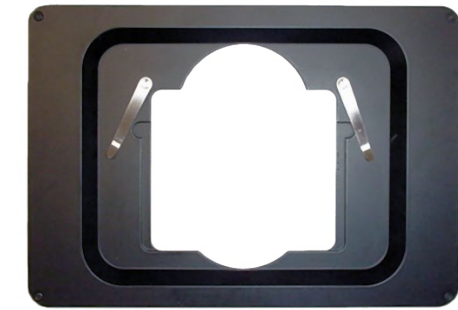

Dual Slide Insert with Clips (I-3027)

The I-3027 slide insert accepts either a single 25 mm x 75 mm (1" x 3") or a 50 mm x 75 mm (2" x 3") slide, and has two silver clips to hold the slide in place. The unit is recessed to place the bottom of a slide about 7.2 mm below the top of the insert.

Depth from top of Insert: 7.2 mm
Overall Thickness: 8.0 mm

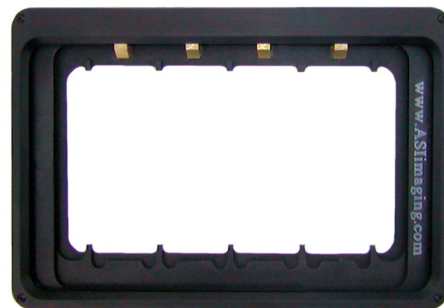

Four-Slide Insert with Brass Sliders (I-3022-B)

The I-3022-B slide insert accepts four 25 mm x 75 mm (1" x 3") slides. The unit is recessed to place the bottom of slides about 7.3 mm below the top of the insert.

Depth from top of Insert: 7.3 mm
Overall Thickness: 8.0 mm

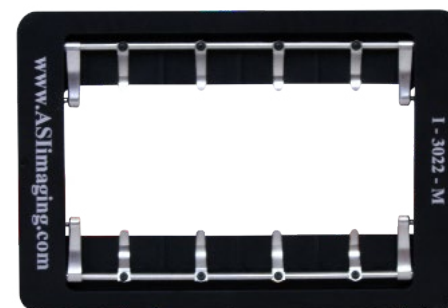

Four-Slide with S.S Clamps Insert (I-3022-M)

The I-3022-M slide insert accepts four 25 mm x 75 mm slides and has individual spring clips on an axle which flips down for secure stability. The unit is recessed to place the bottom slides about 7.1 mm below the top of the insert.

Depth from top of Insert: 7.3 mm
Overall Thickness: 8.0 mm



Triple Slide Insert (I-4021)

The I-4021 slide insert accepts three 24 mm x 50 mm slides/coverslips and has clips on top and bottom to hold slides in place. The unit is recessed to place the bottom of slides about 6.95 mm below the top of the insert.

Depth from top of insert: 6.95 mm
Overall thickness: 8.0 mm



Ring Mount Insert (I-3077)

The I-3077 insert has a C60-RING male attached to the top. The I-3077 is designed to hold ASI's C60-FW and C60-Ring.

Depth from top of insert: N/A
Overall thickness: 13.00 mm

Stage Inserts

160 x 110 mm Stage Inserts



OEM Hole-Style Slide Insert (I-3014 or I-3014-40)

The I-3014 has a 30.5 mm (1.20") hole in the center with two retaining clips and a milled-out area under the opening. It is similar in design to many OEM manual stage tops. The unit is recessed to place the bottom of a slide about 7.1 mm below the top of the insert.

The I-3014-S is a special version of the I-3014 made out of solid steel.

The I-3014-40 is a special version of the I-3014 with a 40 mm (1.57") hole in the center.

Depth from top of Insert: 7.1 mm

Overall Thickness: 8.0 mm



Dual Rotating Slide Insert (I-3096DR, I-3095 or I-3095HR/DR)

The I-3095 Single Rotating Slide Insert accepts a single 25 mm x 75 mm (1" x 3") slide the unit is recessed to place the bottom of a slide about 7.5 mm below the top of the insert and allows the slide to be manually rotated 360 degrees continuously. The insert also holds a 55 mm Petri dish.

The I-3095 HR High-Rise Single Rotating Insert is a special version of the I-3095 which also accept a single 25 mm x 75 mm (1" x 3") slide below the top of the insert. Available for upright microscope that cannot move close enough to achieve correct focusing, although a condenser extender may be needed to obtain Kohler illumination.

Depth from top of Insert: 7.4 mm

Overall Thickness: 8 mm

Stage Inserts

160 x 110 mm Stage Inserts



Dual Rotating Slide Insert (I-4022)

The I-4022 rotating slide insert accepts a 24 mm x 60 mm coverslip or a 25 x 75 mm (1: x 3") slide and it comes with spring clips to hold the slide in place. The unit is recessed to place the bottom of the slide about 7.4 mm below the top of the insert and allows the slide to be rotated 360 degrees continuously.

Depth from top of Insert: 7.4 mm

Overall Thickness: 8.0 mm



Dual Rotating Slide Insert (I-3096DR, I-3093HR/DR or I-3094HR/DR)

The I-3096DR Rotating Slide Insert accepts either a single 25 mm x 75 mm (1" x 3") slide or a 50 mm x 75 mm (2" x 3") slide. The unit is recessed to place the bottom of a slide about 7.4 mm below the top of the insert, and allows the slide to be manually rotated 360 degrees continuously.

The I-3093 HR/DR Medium-Rise Dual Slide Insert is a special version of the I-3096 DR with a slightly shallower recession that places the bottom of a slide about 5.0 mm below the top of the insert. It offers a compress between the closet an upright microscope's objective can approach from above and still obtain Kohler illumination.

The I-3094 HR/DR High-Rise Dual Rotating Slide Insert it is also a special version of the I-3096 DR. It offers a much shallower recession that places the bottom of a slide about 1.5 mm below the top of the insert. Available for upright microscopes that cannot move close enough to achieve correct focusing, although a condenser extender may be needed to Kohler illumination.

Depth from top of Insert: 7.4 mm

Overall Thickness: 8 mm

Stage Inserts

257 x 231 mm Stage Inserts

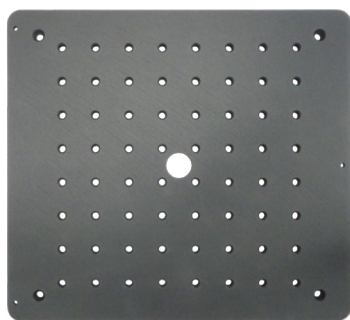

Metric or English Plate Insert for MS-8000 (I-8001 or I-8004)

The I-8001 or I-8004 Metric or English breadboard insert provides a removable base plate for mounting equipment using M6 bolts on 25 mm centers, or 1/4"-20 bolts on 1-inch centers, plus with other smaller mounting holes around the center at common spacings. Also available as English 1/4"-20 holes on 1-inch centers [I-8002].
Depth from top of Insert: N/A
Overall Thickness: 9.5 mm



Motorized Rotary Stage Insert (RS-3000 and I-8004)

This insert has an RS-3000 motorized rotary stage mounted to an I-8004 plate insert, and, in this case, with a 150 mm diameter vacuum chuck affixed. Resolution is 0.12 arc-minutes with ASI's closed-loop DC servomotor drive. The top of the vacuum chuck is approximately 60.4 mm above the top of the insert.
Depth from top of Insert: 60.4 mm
Overall Thickness: 69.9 mm



Glass Plate Insert for MS-8000 (I-8008)

The I-8008 glass insert provides a large specimen area the full size of the insert. It is made of 4.8 mm (3/16") chemically strengthened soda lime float glass.
Depth from top of Insert: N/A
Overall Thickness: 4.8 mm

Stage Inserts

283 x 110 mm Stage Inserts

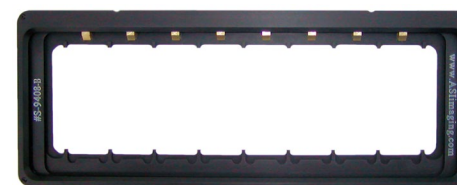

Eight-Side Insert for MS-9500 with Brass Sliders (I-9408-B)

The I-9408-B slide insert accepts eight 25 mm x 75 mm (1" x 3") slides, and has individual spring-loaded brass slider restraints for easy loading and unloading. The unit is recessed to place the bottom of slides about 7.3 mm below the top of the insert. The slides can be easily pre loaded into the insert before installing the insert into the stage. Multiple inserts can be used in this manner to screen a large number of samples.
Depth from top of Insert: 7.3 mm
Overall Thickness: 8.0 mm

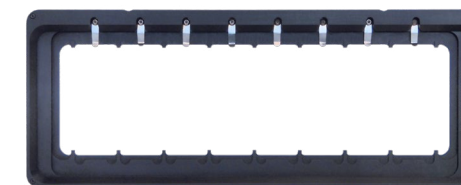

Eight-Side Insert for MS-9500 with Spring Clips (I-9408-C)

The I-9408-C slide insert accepts eight 25 x 75 mm (1" x 3") slides, and has individual spring clips for secure stability. The unit is recessed to place the bottom of slides about 7.3 mm below the top of the insert. The slides can be easily pre loaded into the insert before installing the insert into the stage. Multiple inserts can be used in this manner to screen a large number of samples.
Depth from top of Insert: 7.3 mm
Overall Thickness: 8.0 mm



60 mm or 65 mm Petri Dish Insert (I-9460, I-9465)

60 mm or 65 mm petri dish insert.
Depth from top of Insert: N/A
Overall Thickness: N/A



2X MULTIWELL (I-9409)

I-9409 2X MV Multiwell slide insert will accept two (2) multiwell microplates that are SBS Standard 127.5 mm x 85 mm (5" x 3 1/3") foot print, for example, the 96-well microplate. The unit places the bottom of a wellplate about 6.7 mm below the top of the insert.



Glass Insert (I-9008)

The I-9008 glass insert provides a large specimen area the full size of the insert. It is made of 4.8 mm (3/16") chemically strengthened soda lime float glass.
Depth from top of Insert: N/A
Overall Thickness: 4.8 mm



APPLIED SCIENTIFIC
INSTRUMENTATION

We are constantly improving our products, identifying, and developing new designs to meet the current and future demand of scientific research. Your input to this process is valuable to us, and we would like to hear about any special requirements, feedback, or technical challenge that we could help solve. Contact us with any questions you have.



APPLIED SCIENTIFIC
INSTRUMENTATION



We Create Solutions

2019 PRODUCT CATALOG

Complete Imaging Systems | Modular Microscopes | Microscope Stages
Complete System Solutions