

All Digital
Time Domain Imaging™

QXGA - R10

2K Full colour microdisplay solution

The QXGA-R10 from Forth Dimension Displays is a 2048*1536 pixel microdisplay and spatial light modulator (SLM) based on ferroelectric liquid crystal on silicon (FLCOS) technology for fast amplitude or phase modulation of light.

Configured as a near-to-eye (NTE) display the QXGA-R10 has over 3.1 million pixels in a 21mm (0.88") diagonal microdisplay. Using Time Domain Imaging™ to create high fidelity images, it enables immersive (>100°) Wide Field of View (WFOV) head mounted display systems to be realised without resolvable pixel structure. Colour Calibration functionality allows users to realise a standard colour space easily on the display. Whilst the small form factor drive electronics allows minimum IPD to be achieved.

As a fast SLM it can display binary bit-planes in real time at frequencies greater than 5.7 KHz enabling developments in a range of industrial and scientific applications.

BENEFITS

Time Domain Imaging™ colour and greyscale

Enables 2K or Full HD video window with an OSD above and below

High speed native WUXGA performance at 24-bit colour

Scalable brightness and controllable colour gamut

No sub pixels or colour filters

Small form-factor electronics (51mm wide)

FEATURES

Reflective microdisplay with 0.83" / 21.0 mm diagonal active area

QXGA resolution – 2048 x 1536 pixels with a 8.2µm pitch

High fill factor > 94%

24-bit native colour depth (8-bit per colour)

Image processing options – gamma correction/dither

Fast switching liquid crystal (typically 40µs)

Fast binary mode performance 5.7KHz

Application optimised display addressing sequences

USB Interface for system control

GUI for system set-up and administration

Default DisplayPort video input interface

Frame Repeat Function – allows faster, flexible frame rates at display

Colour Calibration of RGB sub-fields

Daughterboard expansion header for custom system integration

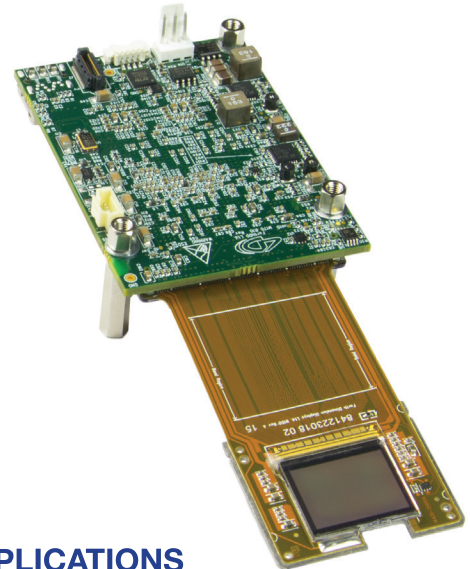

APPLICATIONS

TRAINING AND SIMULATION

- Monocular viewers
- Binocular viewers
- Head mounted displays (HMDs)
- Head-up displays (HUDs)

DEFENCE

- Helmet Mounted Displays (HMDs)

MEDICAL IMAGING

- Image injection for surgical microscopes
- Image guided surgery (IGS)
- Stereoscopic imaging
- Ophthalmic metrology
- Structured illumination microscopy (SIM)

FILM & TELEVISION PRODUCTION

- Full HD electronic viewfinders (EVFs)
- Native 2K EVFs



A subsidiary of Kopin Corporation

All Digital
Time Domain Imaging™

QXGA - R10

2K Full colour microdisplay solution

System Level Overview

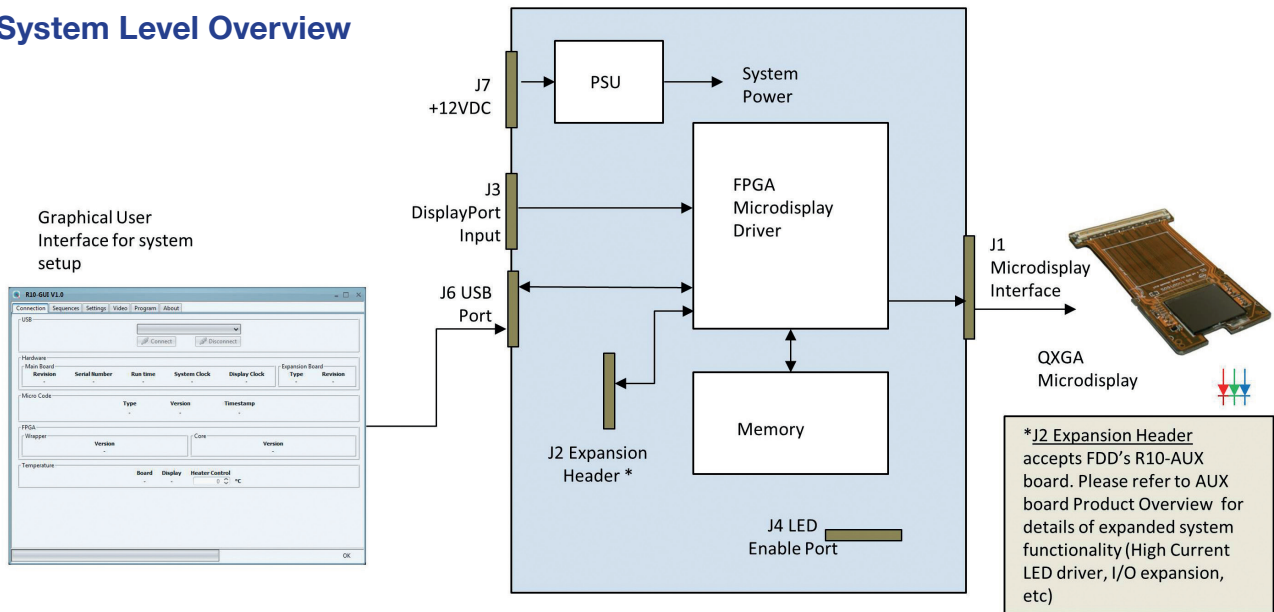

Supported Formats

Video Mode		Refresh Rate (Hz)							
		60	75	85	100	120	150	180	240
XGA	1024×768	✓	✓						
SXGA	1280×1024	✓	✓	✓					✓
UXGA	1600×1200	✓	✓	✓		✓		✓	
1080p	1920×1080	✓							
WUXGA	1920×1200	✓	✓	✓		✓	✓		
QXGA	2048×1536	✓	✓	✓	✓				

Notes

- (1) 24-bit colour
- (2) System is not limited to these modes

If the input video signal has a low frame rate, the Frame Repeat feature may be used to render each frame multiple times, thereby increasing duty-cycle and overall image brightness.

Colour Calibration

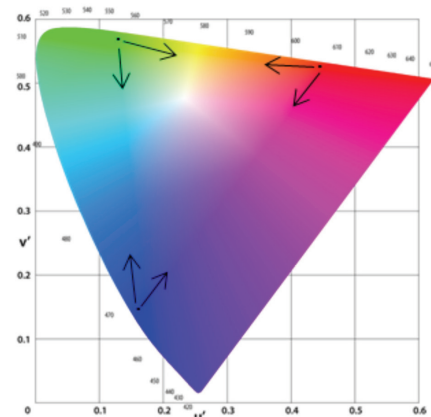

The colour calibration mode allows the colour gamut of the display system to be adjusted. Each primary colour subfield can be illuminated with a controlled amount of each of the other two primary colours. This allows desaturation and colour point adjustment of the red, green and blue primaries.



**FORTH
DIMENSION
DISPLAYS**

A subsidiary of Kopin Corporation